

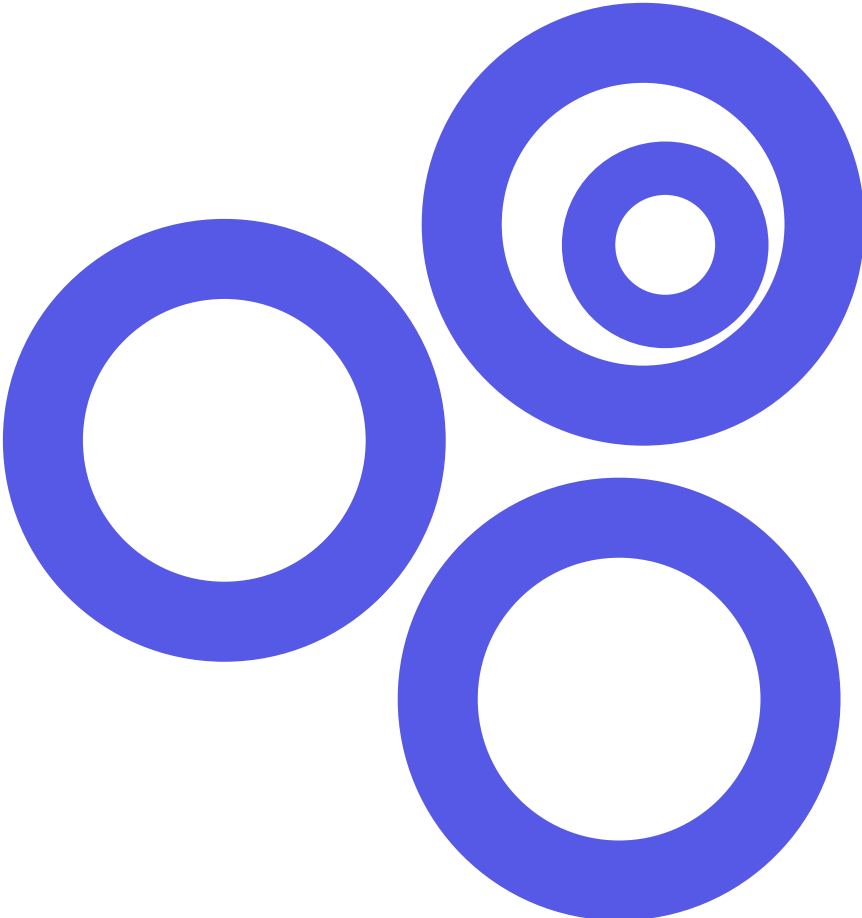

Gijsbert Koren

New Bamboo Product
for the Global Market





New Bamboo Product for the Global Market

An analysis and exploration of opportunities for the production of high value bamboo products by craftsmen for the global market, using a new bamboo material.

G.W. Koren

Graduation report

Graduation report for the completion of the free master program “Integral and Sustainable Product Design and Entrepreneurship” at the faculty of Industrial Design Engineering, TU Delft (the Netherlands).

Graduation committee

Prof. dr. ir. J.C. Brezet (TU Delft)
Prof. dr. H.H.C.M. Christiaans (TU Delft)
J. Binnekade (EvenDimmen)



Index

| | |
|-----------------------------------------|-----|
| Preface | vii |
| Summary | xi |
| 1 Introduction | 1 |
| 2 Bamboo | 7 |
| 3 Sustainability | 11 |
| 4 Global urban market | 15 |
| 5 New bamboo material | 27 |
| 6 Kotwalia community | 39 |
| 7 Applications | 51 |
| 8 Concepts | 61 |
| 9 Wing for an urban (?) windmill | 69 |
| 10 Marketing | 75 |
| 11 Business planning | 79 |
| 12 Sustainability analysis | 83 |
| 13 Conclusions | 87 |
| 14 Discussion | 91 |
| References | 95 |
| Appendices | 99 |



Preface

Make a difference by being free from attachments

I believe that every person can make a difference, by making a choice.

As the creators of our own society, we decide upon the rules, we decide what we do and what we don't. We create our own culture, we create our own beliefs. We even create our own religion.

Our freedom does however have some boundaries, which are to be respected if we want our species to survive for a while. These boundaries are addressed in different theories of sustainable development, of which I personally find The Natural Step one of the best thought through theories. The Natural Step states four system conditions for sustainable development:

“In order for a society to be sustainable, nature's functions and diversity are not systematically

- subject to increasing concentrations of substances extracted from the Earth's crust;*
- subject to increasing concentrations of substances produced by society;*
- impoverished by over-harvesting or other forms of ecosystem manipulation.*

Together, the three first system conditions give a framework for ecological sustainability. It implies a set of restrictions within which the sustainable societal activities must be incorporated. Based on that reasoning, a first-order principle for the society's internal turnover of resources is

formulated - the fourth principle:

- Resources are used fairly and efficiently in order to meet basic human needs worldwide.”*

Two other boundaries to our freedom are our own human nature and nurture, from which we are to escape to be truly free (individually) and in order to be able to live by The Natural Step's system conditions (collectively).

I am far from being free, but I do believe I can make a difference. I hope my graduation project inspires others to make a difference as well.

During my study period and the execution of my graduation project, there have been many people who made a difference to me. I would like to thank them for their inspiration and support.

I would like to thank my graduation committee (Han Brezet, Henri Christiaans and Joachim Binnekade) for believing in me and this graduation project.

In India I received a lot of support from different organisations. I would like to thank TBDC, INBAR and NID for their hospitality. I would like to thank MP Ranjan for giving me warm support when I needed it the most and for providing critical insights into the world of bamboo crafts.

In the Netherlands I also received a lot of support from different organisations and individuals. I would like to thank Jules

Janssen, Charley Younge and Arjan van der Vegte for the discussions that stimulated me in taking a realistic commercial approach in this project. I would like to thank Pablo van der Lugt for providing so many insights with his extensive PhD research and for laying a strong foundation for further research and development. I would like to thank Jan Pieter Duvekot for refreshing my knowledge about mechanics. And I would like to thank everybody else who helped me during discussions and by participating in brainstorm sessions.

The final prototype and field testing has been supported by Bosman Watermanagement BV, ComposietenLab INHolland Delft and Rabobank Hoeksche Waard. Thank you for your support. I hope you, and the other organisations involved, will look into possibilities in taking (parts of) this project to the next level.

I would like to thank my business partners at CrowdAboutNow and other ventures in which I am involved for understanding my determination in finishing my master program. Your patience will be rewarded!

Last, but most important, I would like to thank my parents for supporting me during my complete study period and for being a warm home in Amsterdam. I would like to thank my girlfriend Licia Jasperse for always supporting me from closeby in the Netherlands and India. And I would like to thank Licia's parents for supporting with the development and testing of the prototype and for visiting Licia and me in India.

And if you're reading this, I would like to thank you for taking the time to read my graduation report. Feel free to use everything you can and spread anything that seems useful to you.

Gijsbert Koren
Rotterdam, August 2010





Summary

Samenvatting

Bamboo

Bamboo is a material with a high - but latent - potential for application in a plethora of products. Early adopters in the global market are already using bamboo in a wide variety of products, currently bamboo is mainly used for basketry and flooring. Research in the area of bamboo product development for the Western market has shown that there are several factors that limit the growth possibilities of bamboo products for the Western market:

- Low quality (and too much variation in quality).
- Low production capacity (and unreliable capacity) in producing countries.
- Aesthetics of bamboo products do not fit in the Western market.
- Use of toxic materials for preservation and gluing that are not allowed on the Western market and a high environmental burden of transport to the West.

India

India has a tradition of bamboo craftsmanship and one of the largest natural bamboo reserves. It is a challenge to find an innovative way of making successful bamboo materials and products for the global urban market that benefit the local producers in India.

Plybamboo and Strand Woven Bamboo are the first two high quality bamboo materials that are industrially produced and used for products on the Western market. In India

Bamboe

Bamboe is een materiaal dat een latente behoefte kent en toepassingsmogelijkheden heeft in veel verschillende producten. Innovatieve spelers op de globale markt gebruiken bamboe al in allerlei producten. Momenteel wordt bamboe vooral toegepast in mandjes en vloeren. Onderzoek naar bamboe productontwikkeling voor de Westerse markt heeft aangetoond dat er verschillende factoren zijn die de groei mogelijkheden van bamboe producten op de Westerse markt belemmeren:

- *Lage kwaliteit (en te veel variatie in kwaliteit).*
- *Lage productie capaciteit (en onbetrouwbare capaciteit) in producerende landen.*
- *Het gebruik van giftige materialen voor conservering en verlijming die niet toegestaan zijn op de Westerse markt en daarnaast een hoge milieu impact van transport naar het Westen.*

India

India heeft een traditie van bamboe vakmanschap en heeft een van de grootste natuurlijke oppervlakten bamboe bos. Het is een uitdaging om een innovatief materiaal en product voor de globale stedelijke markt te verzinnen die geproduceerd kunnen worden door lokale arbeiders in India.

Plybamboo en Strand Woven Bamboo zijn de eerste twee bamboe materialen van

there are more bamboo materials available, however most of them are not fitting the Western and global urban market. One example of a high potential new material is Moulded Bamboo Mats. The specific quality of bamboo mats is the ability to give it any shape you like. Bamboo mats can be fixed in a mould and glued together to remain in that shape. With this technique, one may construct geometrically complex structures: in one piece, at low cost, low weight and with yet very good mechanical properties.

The Kotwalia community in the southern part of Gujarat (India) is an example of a tribal community of craftsmen that produce handmade bamboo products. The Kotwalia community is already making a product from Moulded Bamboo Mats (MBM). This product is however still of a very low value. This means that there are possibilities for production and opportunities for improvement.

Applications

Through discussions, benchmarking and brainstorming, several interesting product ideas have been generated. Many more areas of applications could be thought of by other product developers. For this project, the three most interesting applications of MBM are:



hoge kwaliteit die industrieel geproduceerd worden en gebruikt worden voor producten voor de Westerse markt. In India zijn meer bamboe materialen beschikbaar, maar deze passen meestal niet in de Westerse of globale stedelijke markt. Een voorbeeld van een materiaal met veel potentie, is Moulded Bamboo Mats. De specifieke kwaliteit van bamboe matten is de mogelijkheid om er elke vorm aan te kunnen geven. Bamboe matten kunnen in een mal gedruwd worden en door middel van lijm in die vorm blijven. Met deze techniek is het mogelijk om geometrisch complexe vormen te maken, uit een stuk, voor lage kosten, met een laag gewicht en toch met goede mechanische eigenschappen.

De Kotwalia gemeenschap in het zuiden van Gujarat (India) is een voorbeeld van een inheemse stam die al een product maken van Moulded Bamboo Mats (MBM). Het product dat gemaakt wordt is echter van erg lage waarde. Dit betekent dat er mogelijkheden zijn voor verbetering.

Toepassingen

Door middel van discussies, vergelijkingen met andere producten en brainstorm, zijn er verschillende toepassingen bedacht. Andere ontwerpers kunnen nog veel meer toepassingen verzinnen, maar voor dit project zijn de drie meest interessante toepassingen:

iPhone cover

The iPhone is a fashion accessory, business tool and productivity device with opportunities for customization by using a protective cover. MBM is the perfect material for an iPhone cover and would give it a natural look. An iPhone application could be developed to communicate the story behind the product and the possibilities of bamboo.

Chair

The furniture market is a solid market and classic field of operation for product designers to showcase the possibilities of a new material. Design and details make a chair stand out. Details could include: partly treating the mats with resin to create a product that is partly rigid and partly flexible, using 3D weaving to create more extreme shapes, using an open weaving pattern or integrating an electricity wire into the weaving.

Wing for an urban windmill

Urban windmills are a tool for companies and organisations to communicate their environmental consciousness and to create a green image. The capacity of urban windmills is quite low compared to larger windmills, due to the size and location of installation, but they are a step into the direction of the future of energy, where we will need renewable and decentralized solutions.

Wing for an urban (?) windmill

For this project, wings for a windmill are found to be the most interesting application. A windmill - of which parts are being made in a rural area in India, where energy is scarce and the demand for electricity is increasing - could also function very well in the local surroundings and could also be sold on other rural markets.

A windmill that is (partly) made from bamboo is a truly sustainable product:

- The windmill generates renewable energy.
- The windmill wings are made from a

iPhone hoesje

De iPhone is een mode accessoire, zaken tool en productiviteits apparaat die door middel van een beschermend hoesje gecustomized kan worden. MBM is het perfecte materiaal voor een iPhone hoesje en geeft de telefoon een natuurlijke uitstraling. Een iPhone applicatie zou ontwikkeld kunnen worden om het verhaal achter het product en bamboe in het algemeen te vertellen.

Stoel

De meubelmarkt is een solide markt en klassiek werkveld voor productontwerpers, om te laten zien wat de mogelijkheden van een nieuw materiaal zijn. Ontwerp en details zorgen er voor dat een stoel opvalt. Details zouden kunnen zijn: deels behandelen van matten met een hars om een product te maken dat deels stijf en deels flexibel is, 3D weven om meer extreme vormen te creëren, open weefpatronen gebruiken, of elektriciteitsdraden integreren in de weefstructuur.

Wiek voor een stedelijke windmolen

Windmolens voor stedelijke gebieden, zijn tools voor bedrijven en organisaties om te laten zien dat ze duurzaam bezig zijn. De capaciteit van deze windmolens is laag vergeleken met grotere windmolens, vanwege het formaat en de plaatsing in bebouwde omgeving. Desalniettemin zijn ook deze windmolens een stap in richting van de toekomstige energievoorziening en bovendien een decentrale oplossing.

Wiek voor een stedelijke (?) windmolen

Voor dit project, zijn de wieken van een windmolen de meest interessante toepassing. Een windmolen - waarvan onderdelen in een ruraal gebied in India gemaakt worden, waar energie schaars is en de behoefte aan elektriciteit toeneemt - kan ook een toepassing zijn voor een rurale markt.

Een windmolen die (deels) gemaakt is van

potentially completely sustainable material.

- The wings generate a fair income for the tribal craftsmen who produce them.

The product communicates the environmental and social consciousness of the owner, which makes it the perfect image building product.

The fact that this high-tech and high quality product is handmade, adds to the positive story behind the product

Trends and developments

The product fits with a few trends and developments.

Global citizens

The youngest generations (aged 0-25) are international citizens with an opinion about global topics and discussions. The generation gives rise to all types of social entrepreneurs and intrapreneurs, supporting local and decentralized production of products and decentralized energy generation.

Innovation Boom

The need to get more value for money asks for innovative and basic products, which can be oriented towards a niche market. The bamboo wing is an unexpected innovation that greatly reduces the price of the original wings from 80 to 20 euro.

Water and energy supply shortages

Urbanization and sustainability pose challenges upon society, of which one is the need to cover energy supply shortages. A windmill could (partly) solve this challenge.

bamboe, is om drie redenen een duurzaam product:

- *De windmolen wekt duurzame energie op*
- *De wieken van de windmolen zijn gemaakt van materiaal dat in potentie compleet duurzaam kan zijn.*
- *De wieken genereren inkomen voor de ambachtslieden.*

Het product communiceert het milieu en sociale bewustzijn van de eigenaar, waardoor het een perfecte imago versterker is.

Het feit dat de toepassing high-tech en van hoge kwaliteit is, terwijl het product met de hand gemaakt is, voegt ook een positief element toe aan het verhaal achter het product.

Trends en ontwikkelingen

Het product past binnen een aantal trends en ontwikkelingen.

Internationale burgers

De jongste generatie (leeftijd 0-25) bestaat uit internationale burgers met een opinie over internationale onderwerpen en discussies. De generatie zal allerlei typen sociale ondernemers voortbrengen, die lokale en decentrale productie stimuleren en ook decentrale opwekking van energie.

Innovatie Knal

De behoefte aan meer waarde voor minder geld vraagt om innovatieve en simpele producten die zich op een niche markt oriënteren. De wiek van bamboe is een onverwachte innovatie die de kostprijs van



Remarkable enabler application

The bamboo wing should be a so-called enabler application, showing the unique possibilities of the material, in order to start commercialisation of BMB.

The product, the production process and the value chain are quite simple, which is positive for an enabler application. The fault tolerance is moderate and the product has a high visibility, which is also positive.

The surprised reactions on the bamboo wings indicate that the bamboo wings demonstrate the qualities of bamboo in a new way and provides the material with credibility.

The product is generating quite some media attention, which indicates the remarkability of the product.

Commercial viability

Competing with the original windmill wing which costs €80, the bamboo wing will cost approximately €20, which leaves ample opportunity for profits (if the value chain doesn't become too complex).

During prototyping, a very simple production method of hand lay-up moulding on a flat mould was discovered for this product.

The bamboo wing seems to be an interesting opportunity for a social entrepreneur and other stakeholders involved. Let's see what the future brings.

de originele wiek dramatisch terugbrengt van 80 tot 20 euro.

Tekorten in toelevering van water en energie

Urbanisatie en duurzaamheid creëren uitdagingen voor onze samenleving. Een voorbeeld van een uitdaging is tekorten aan energie toelevering. Een windmolen kan dit tekort (deels) oplossen.

Bijzondere toepassing

De bamboe wiek is een zogenaamde bijzondere toepassing die laat zien wat de unieke eigenschappen van het materiaal zijn, waardoor de commercialisatie van BMB gestimuleerd kan worden.

Het product, het productie proces en de waardeketen zijn vrij simpel, wat erg voordelig is voor een bijzondere toepassing. De fout tolerantie is redelijk en het product heeft een grote zichtbaarheid, wat ook positief is.

De verraste reacties op de bamboe wieken, geven aan dat de wieken de kwaliteiten van bamboe op een nieuwe manier laten zien en het materiaal geloofwaardigheid geven. Het product krijgt bovendien aardig wat media aandacht, wat aangeeft dat de wiek een bijzondere toepassing is.

Commerciële haalbaarheid

De competitie met de originele wiek die €80 kost, tegen ongeveer €20 voor de bamboe wiek, biedt genoeg mogelijkheden voor winst (mits de waardeketen niet te complex wordt).

Tijdens het maken van het prototype is een simpel productie proces van handmatig lamineren op een platte mal gevonden.

De bamboe wiek lijkt haalbaar en is een mooie kans voor een sociale ondernemer.

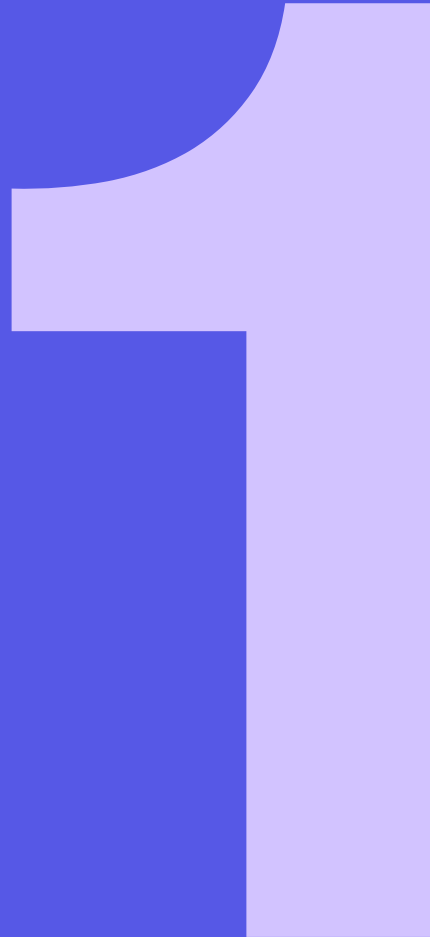

| | |
|----------------------------|---|
| 1.1 Graduation assignment | 1 |
| 1.2 Starting points | 2 |
| 1.3 Organisations involved | 3 |
| 1.4 Project execution | 5 |
| 1.5 Conclusion | 6 |

Introduction

This chapter is an introduction to the graduation project. It gives an overview of the assignment, the starting points are explained, the organisations involved are summed up and a description of the project execution is given.

1.1 Graduation assignment

Bamboo is a material with a high - but latent - potential for application in a plethora of products. Early adopters in the Western market are already using bamboo in a wide variety of products. However, currently bamboo is mainly used for basketry and flooring. Research in the area of bamboo product development for the Western market has shown that there are several factors that limit the growth possibilities of bamboo products for the Western market:

- Low quality (and too much variation in quality).
- Low production capacity (and unreliable capacity) in producing countries.
- Aesthetics of bamboo products do not fit in the Western market.
- Use of toxic materials for preservation and gluing that are not allowed on the Western market and a high environmental burden of transport to the West.

Recently, attention is growing with respect to the possibilities of combining bamboo and Western design. India has a long tradition of bamboo craftsmanship and one of the largest natural bamboo reserves. It is a challenge to find an innovative way of making successful

bamboo products for the global urban market that also benefit the tribal craftsmen in India.

The growing demand for sustainable products make bamboo an interesting material for application in global urban markets. Growing urban areas - with megacities as an extreme form - require their own solutions to sustainability issues; how can tribal bamboo craftsmen from India provide solutions?

Assignment

- Analyse and explore opportunities for the production of high value bamboo products by Indian craftsmen for the global urban market, using a new bamboo material.
- Design a bamboo based product for the global urban market, that clearly shows the unique qualities of the new bamboo material and benefits the tribal craftsmen in India.

1.2 Starting points

Figure 1 gives a clear overview of the starting points, which are:

- **Bamboo product:** A bamboo based product will be the result of this project.
- **Sustainability:** Designing sustainable products is - in my view - the moral obligation of every designer.
- **Designed for the global urban market.**
- **New bamboo material:** A bamboo material that is currently not available on the Western market will be used for the product.
- **Income generation for tribal craftsmen:** The target producers for the product are tribal craftsmen from India.
- **Me:** I will always keep in mind the potential for starting a company to produce and sell the product.



Figure 1
Starting points

1.3 Organisations involved

Different organisations were involved in this graduation project. An overview is given in the figure below.

TU Delft and EvenDimmen are at the center of this project. TU Delft as educational institution and EvenDimmen as client.

TU Delft

TU Delft is the largest and most all-round university of technology in the Netherlands. The university also enjoys a good international reputation. The Industrial Design Engineering programme in Delft is the oldest of its kind and has existed as an

academic programme for over 35 years.

EvenDimmen

EvenDimmen is a consultancy agency with a focus on efficiency and sustainability measures to reduce the environmental impact of the business operations of their clients. EvenDimmen uses the DIM model: Direct measures, Investments and Mentality changes. Next to consultancy work, EvenDimmen is active in product development and has developed a bio-gasifier for an Australian client and a zero energy indoor air heater.

Other organisations that have contributed to this project are positioned around the center.

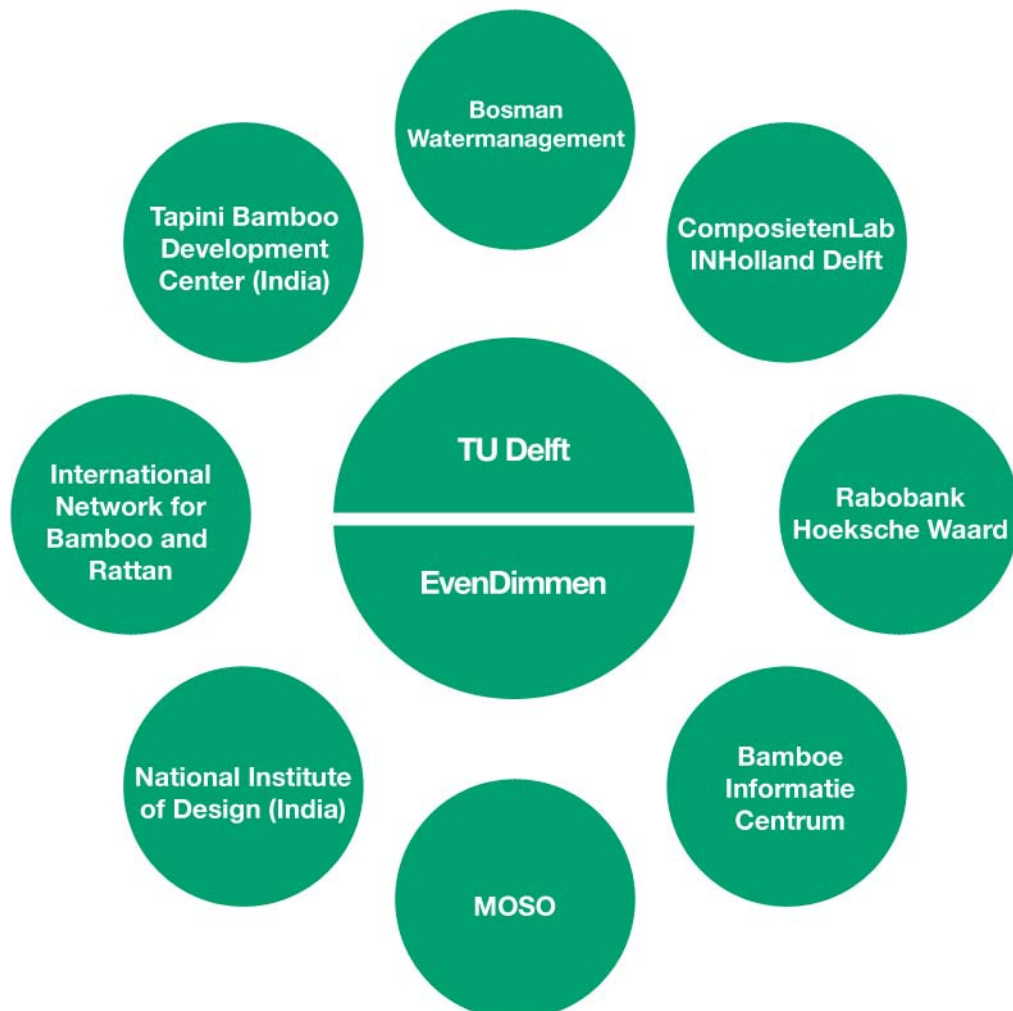

Figure 2
Organisations
involved

Bosman Watermanagement

Bosman Watermanagement designs, manufactures and installs a wide variety of systems for the control of surface water levels and treatment of waste water. Bosman produces a wind water mill, which is the most frequently seen type of wind mill in the Dutch landscape. Bosman has installed thousands of wind water mills since 1929, many of which are still in use.

Bosman contributed to this project by providing materials and knowledge and installing the bamboo wings.

INHolland ComposietenLab Delft

The ComposietenLab is part of INHolland Delft and is a facility for education and research. The lab offers practical knowledge and training in the area of designing and engineering composite products for educational and commercial purposes. The ComposietenLab contributed to this project by providing materials, help and advice in making the bamboo wings.

Tapini Bamboo Development Center (TBDC)

TBDC's mission is to create livelihood opportunities which will enable tribal households in South Gujarat (India) to cross the poverty barrier in 5 years, through bamboo based eco income generation activities, supported by an institutional mechanism for further outreach and development of tribals through bamboo. TBDC contributed to this project by being a host in India and source of knowledge on bamboo crafts.

International Organisation for Bamboo and Rattan (INBAR)

INBAR is an international organization, dedicated to improving the social, economic, and environmental benefits of bamboo and rattan. INBAR connects a global network of partners from the government, private, and not-for-profit sectors in over 50 countries, to define and implement a global agenda for sustainable development through bamboo and rattan. The mission of INBAR is to improve the well-being of producers and users of bamboo and rattan within the context of

a sustainable bamboo and rattan resource base by consolidating, coordinating and supporting strategic and adaptive research and development.

INBAR contributed to this project by being a host in India and a source of knowledge on bamboo crafts.

National Institute of Design (NID)

NID is a design school in India. The Government of India set up the National Institute of Design in 1961 as an autonomous national institution for research, service and training in Industrial Design and Visual Communication. NID has a bilateral agreement with TU Delft's faculty of Industrial Design Engineering.

NID contributed to this project by offering me a position as exchange student and the opportunity to use their knowledge and facilities.

Bamboe Informatie Centrum

Bamboe Informatie Centrum develops and sells bamboo materials.

Bamboe Informatie Centrum contributed to this project by providing knowledge on materials and the bamboo market.

MOSO

MOSO is specialized in the development of innovative and trendsetting products made of bamboo. The two product categories of MOSO are: flooring and panel materials.

MOSO contributed to this project by providing knowledge on materials and the bamboo market.

Rabobank Hoeksche Waard

Rabobank is an international financial services provider operating on the basis of cooperative principles. Rabobank puts the common interests of people and communities first.

Based on its commitment to those interests, Rabobank aims to be a driving and innovating force that contributes to the sustainable development of prosperity and well-being.

Rabobank Hoeksche Waard contributed to this project by giving the opportunity to use their Bosman wind water mill to demonstrate the bamboo wings.

1.4 Project execution

After formulating the starting points, literature research and consultations of experts in the field of bamboo have been performed to get a deep understanding of the field of bamboo in general and bamboo product development in specific.

Research into bamboo crafts is performed in India, in the city of Ahmedabad and in the Tapi district in Southern Gujarat, where the Kotwalia community is living.

Opportunities for product development are generated and analysed through peer interviews, field studies and brainstorm sessions.

A showcase product is selected by evaluating different opportunities on the initial starting points.

For this showcase product, a working prototype is made and tested in the context.

1.5 Conclusion

This introductory chapter concludes with a preliminary list of criteria for the final product:

| Criteria |
|------------------------------------------------|
| Sustainable |
| Fit the global urban market |
| Use a new bamboo material |
| Production possible by tribal craftsmen |
| Profitable for tribal craftsmen |
| Commercial potential for me as an entrepreneur |



Figure 3
Chronological
process of
execution

2

| | |
|------------------|---|
| 2.1 Bamboo plant | 7 |
| 2.2 Processing | 8 |
| 2.3 Materials | 9 |

Bamboo

This chapter gives a brief introduction into bamboo as a plant and as a material for product development.

2.1 Bamboo plant

Because of its high growth rate and easy processing, bamboo is a promising renewable resource. Bamboo's good mechanical properties, low costs, abundant availability in developing countries and potential use in a multitude of applications show the potential of this versatile resource. Moreover, due to its extensive root network, bamboo as a plant is a good erosion controller and water table preserver.

From a botanical point of view, bamboo belongs to the grasses, the Graminea, and is therefore not a tree. It is estimated that around 1000-1500 different species

of bamboo exist. There are considerable differences between species (see figure 4) in size, color, node distribution and configuration, mechanical properties and climatic preferences. Some giant species may reach up to 30 meters with cross sections of up to 30 centimeters per stem, whereas some species do not reach above 1 meter in height and 1 centimeter in diameter.

Bamboo mainly grows in countries with a tropical to subtropical climate. Giant bamboo species, which have the most potential for industrial processing and economic development, mainly derive from developing countries (or emerging economies). In China and India the largest stocks of the worldwide 20 million hectares of bamboo forest can be found.



Figure 4
Various bamboo species

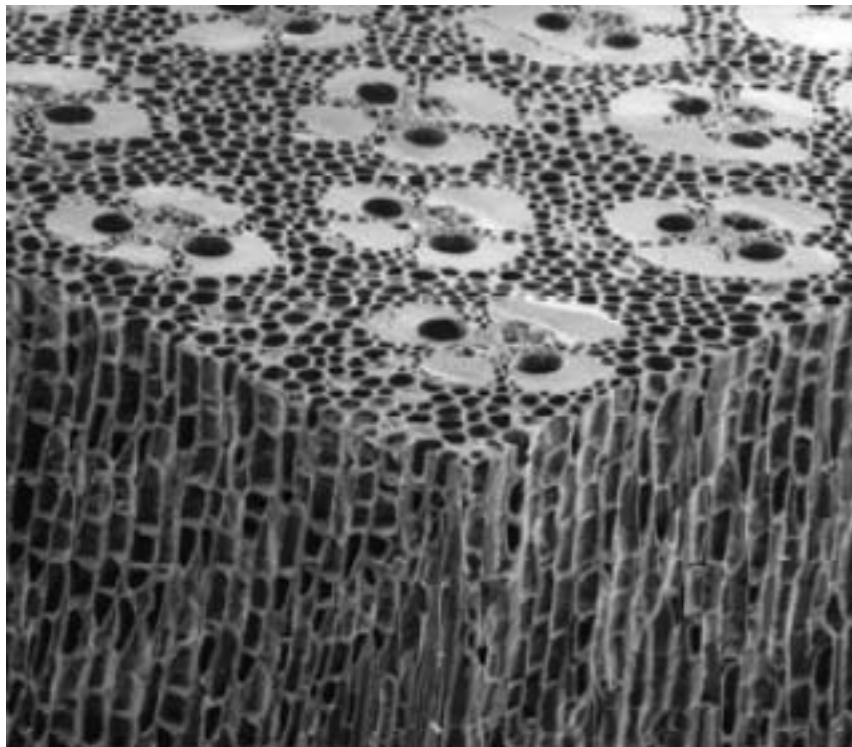

Figure 5
Microscopic three dimensional representation of bamboo tissue consisting of parenchyma cells, vascular bundles (black) circled by fibers (light and solid) (Van der Lugt 2008)

In the cross section of a bamboo stem, we can identify cellulose fibers (40%), vascular bundles (10%), and the in-between parenchyma tissue (50%), which largely consists of lignin (see figure 5). The fibers and the parenchyma tissue together function as a composite material: the cellulose fibers make the bamboo strong, functioning as the reinforcement in the matrix of the thin-walled parenchyma cells, similar to steel in reinforced concrete. The fibers run in a longitudinal direction around the vascular bundles. The outer wall of the stem consists of a thin silica layer of 0.25 mm that protects the stem. The outer and inner walls of the stem are also covered with a waxy layer. The solid patches (see figure 5) are the cross-sections of the cellulose fibers.

The density of fibers increases from the inside toward the outside, where they are most needed to carry moments of force due to external mechanical loading. After about 4 years, the walls of the fiber cells have become mature and solid and the bamboo stem is ready to be felled for construction purposes.

2.2 Processing

Besides the many traditional applications for local markets and low end export markets in which bamboo in its natural form (stem) is usually used, through industrial processing new bamboo materials, such as Plybamboo and Strand Woven Bamboo (see appendix 1) have become available since the 1990s. Plybamboo and Strand Woven Bamboo can be used for applications in high end markets in the West as well.

There are quite some people advocating the use of bamboo. After years of research and development, the promise of bamboo as a sustainable material with endless applications seems to be overestimated (Dufrenot 2009). Plybamboo is the most used advanced bamboo material in the West and is mainly used for flooring. If we look at the flooring market, the sales of bamboo flooring panels is however still only 1% of the sales of wooden flooring panels (Van der Lugt and Lobovikov 2008).

2.3 Materials

Since the 1990s new bamboo materials such as Plybamboo and Strand Woven Bamboo have become available on the international market. More materials are in development, or are available since long on local markets in bamboo producing countries. Different bamboo materials have different properties and can have different fields of application. Appendix 1 gives an overview of bamboo materials, its properties and its applications.

All bamboo materials are characterised by somewhat the same material properties and from a mechanical point of view, it can be said that bamboo scores good on:

- Tensile strength
- Stiffness
- Flexibility
- Weight
- Hardness

Bamboo scores less on:

- Compressive strength
- Fatigue (Thwe 2003, Van der Lugt 2007)

Strand Woven Bamboo still needs development, before it can be introduced on a large scale on the market, and is expected to be the first bamboo for outdoor use, due to its weather resistance (source: personal communication with developer: Charley Younge, Bamboe Informatie Centrum, Schellinkhout, the Netherlands).

In bamboo producing countries, there are other bamboo materials available, however they currently do not fit the Western market, due to:

- Low quality (and too much variation in quality).
- Low production capacity (and unreliable capacity) in producing countries.
- Aesthetics of bamboo products do not fit in the Western market.
- Use of toxic materials for preservation and gluing that are not allowed on the Western market and a high environmental burden of transport to the West.

In other words: the materials have to go through a development phase before they can be introduced on the Western market and it is of course not guaranteed that they will be successful (source: personal communication with expert: dr. Jules Janssen). It is challenging to develop bamboo products for the competitive and demanding global urban market first. In case of success, other markets will follow.

3

| | |
|-------------------------------|----|
| 3.1 Sustainability theories | 11 |
| 3.2 Bamboo and sustainability | 12 |
| 3.3 Conclusion | 13 |

Sustainability

This chapter introduces the concept of sustainability and two tools that are related to product design: LCA and Cradle to Cradle. The chapter also contains a section on bamboo and sustainability.

3.1 Sustainability theories

Our (systematic over-) consumption is effecting the ecosystem on Earth. We are destroying essential parts of the system, overharvesting elements from the system we consider to be our resources and polluting it with chemicals. It seems like we are doing 'harm' to the ecosystem we live in, but nothing is further away from the truth. The ecosystem will adjust itself. The reason why we should worry about our impact on the ecosystem, is that we are destroying our own habitat and compromise the ability of future generations to meet their needs.

Sustainability is about development that meets the needs of the present without compromising the ability of future generations to meet their own needs (Brundtland et al. 1987).

System conditions for sustainable development

In order for a society to be sustainable, nature's functions and diversity are not systematically

- subject to increasing concentrations of substances extracted from the Earth's crust;
- subject to increasing concentrations of substances produced by society;
- impoverished by over-harvesting or other

forms of ecosystem manipulation.

Together, the three first system conditions give a framework for ecological sustainability. It implies a set of restrictions within which the sustainable societal activities must be incorporated. Based on that reasoning, a first-order principle for the society's internal turnover of resources is formulated - the fourth principle:

- Resources are used fairly and efficiently in order to meet basic human needs worldwide (Holmberg and Robèrt 2000).

For a designer, these abstract system conditions for sustainable development have to be translated into concrete do's and don't's. One *don't* could be a list of toxic materials you shouldn't use, while a *do* could for instance be to use recycled materials. Almost all do's can be summarized by:

- Dematerialisation
- Substitution (Robèrt et al. 2001)

Dematerialisation is about using less material to achieve the same result, while substitution is about using an environmental friendly alternative. To say it in popular language: use less stuff and use less harmful stuff.

It is however impossible to make an exhaustive checklist or design methodology to guarantee a sustainable product as endresult, because:

- A product lifecycle is a complex system; factors interact with each other and a factor can be of negative influence in one system and of positive influence in the other.
- A product lifecycle is not a closed system; it is influenced by unpredictable factors from

outside the system.

There are some tools available to help designers to develop more sustainable products. Two very interesting tools are Cradle to Cradle and LCA.

Cradle to Cradle

Cradle to Cradle is built on the premise 'learning from nature' and aims to design in such a way that 'waste equals food'. The shared language of Cradle to Cradle, with its focus on the creation of technical metabolisms, provides the unique potential to trigger conversations around the enabling of a societal infrastructure that supports organisations in their transition towards participation in cyclical supply chains. The three tenets around which Cradle to Cradle is built are:

- Waste = food
- Use current solar income
- Celebrate diversity

The Cradle to Cradle approach specifically focuses on the concept of biological and technical metabolisms as a method to close material loops. In the biological metabolism, the nutrients that support life on Earth - water, oxygen, nitrogen, carbon dioxide - flow perpetually through regenerative cycles of growth, decay and rebirth in such a way that waste equals food. The concept of Cradle to Cradle suggests that the technical metabolism can be designed to mirror natural nutrient cycles; as a closed-loop system in which valuable, high-tech synthetics and mineral resources circulate in an endless cycle of production, recovery and remanufacture (McDonough and Braungart 2002).

For designers this means:

- Use non-toxic materials
- Design products for disassembly (so the components can be easily replaced or separated for recycling)
- Recycle all materials (for instance by leasing instead of selling a product)

LCA

A lifecycle assessment (LCA) is the investigation and evaluation of the environmental impacts of a given product or service caused or necessitated by its existence. It is traditionally a cradle to grave analysis and focuses on aspects like:

- Material use
- Processing of materials
- Packaging of the product
- Transport of the product
- Energy consumption during use
- Disposal

An LCA can be performed to continuously improve products and to determine focal points for improvement of existing products or concepts.

3.2 Bamboo and sustainability

Bamboo can be a sustainable alternative for hard wood and other materials. However, using bamboo doesn't guarantee a sustainable product.

Bamboo harvesting should be done in a proper way, to make it a sustainable source of income and the labourers who are involved in the early steps of the production chain should get paid fair wages. While processing the material, the additives that are used for gluing and preservation, should be as little harmful to the environment as possible. For preservation, preservatives from the wood industry, like CCB (copper-chrome-boron) are being used. CCB is a relatively friendly material. The waste of preservation processes is currently even used as fertilizer (Janssen 2000). For the glue that is used in many bamboo materials, the manufacturers have not found an eco friendly material yet and are looking for a bio-based resin to replace epoxy and other resins (source: personal communication with developer: Charley Younge, Bamboe Informatie Centrum).



Figure 6
The core of the
Cradle to Cradle
theory (a closed
material loop)

Ecological and social sustainability issues:

- Harvesting as a sustainable source of income.
- Fair wages for labourers at early steps in production chain.
- Environmental friendly processing; preservation and gluing.

3.3 Conclusion

The criterium for making the product sustainable, can be split into two new criteria:

Sustainability criteria

Ecologically sustainable

Socially sustainable

4

| | |
|-------------------------------------|----|
| 4.1 Target consumer | 15 |
| 4.2 Trends | 16 |
| 4.3 Urbanization and sustainability | 20 |
| 4.4 Conclusion | 24 |

Global urban market

This chapter is about the target market for the bamboo product and the consumers on this market, consumers trends and about a future scenario of sustainable mega cities of the future and globalisation.

4.1 Target consumer

The target consumer for the new bamboo product is the global urban consumer. The

global urban citizen of the future is (next to citizen of a large metropolitan area) an innovator, highly educated, prosperous and in the age group of 20-35 (used in demographic segmentation systems like Acorn, Prizm and Mosaic). The focus is on consumers who experience a tension between the importance of their externally oriented status and their internally oriented authenticity, which is about consciousness, values and norms.



Figure 7
Target consumer
characteristics

Traditionally, social status was defined by four factors: education, occupation, sex and marital status (Hollingshead 1975). Descent was (and for some it still is) a very important factor. For the post-material urban citizen, these factors no longer hold (Inglehart, 1971). Income and education are very important, but most of all a network of 'important people' adds to the social capital of a person or firm (Burt, 2005). There is a shift from money (plutocracy) towards education and experience determining one's status (also known as a meritocracy).

Brand consciousness and convenience are key factors in determining product preferences of the global urban citizen. Brands and its promises (a certain lifestyle and image) are sometimes more important than product functionality. Lifestyle and image are actually new product functionalities. Convenience is about making a product more efficient, reducing human handling and making the remaining interaction an enjoyable exercise.

Authenticity is about being faithful to inner ideas, despite any external pressures. Spirituality, sustainability and family are part of a person's authentic being. Every human being seems to be looking for answers to existentialistic questions, with spirituality (and sometimes religion) as an answer. Sustainability and family are about surviving and thriving as a species and as a close social group.

Sustainability also reflects our sense of guilt concerning the deterioration of the ecosystem and climate change. While sustainability is about the future, nature is about here and now and being aware of the system we are living in. Sustainability is a dominating action, while enjoying nature is very humble in essence.

Culture (as in art) is a reflection of knowledge, belief and values.

4.2 Trends

Trends are a manifestation of new enablers unlocking existing human needs.

The focus on the urban market and sustainability, match with two major global trends that will keep on enduring for the coming decades: urbanization and sustainability.

An overview of consumer trends (Insight Instore 2009 and Trendwatching.com 2008-2009):

Buying the experience

There is a shift from buying products towards buying experiences, which implies a dematerialisation, or even a shift from owning goods towards using goods. The experience economy (Pine 1999) started in tourism and architecture, but is expanding to other fields too. Leasing art and expensive cars, enjoy shopping, dining, a great holiday or outdoor sports activities are all experiences.

Music concerts are the new ways for artists to earn money; you can't download a concert, you can only experience it. The *beertender* from Heineken and Krups gives consumers the experience of tapping your own beer at home. *Social media* like Twitter and Facebook are our personal media channels to share our experiences.

Econcierge & ecoeasy

More and more products are about assisting households to go green, like energy monitoring and saving systems, combined with roof top PV panels. Now environmental consciousness is growing, sustainable products can finally be sold at a large scale. Behind closed doors, manufacturers are making products sustainable, without consumers ever knowing about it, since rules and regulations are getting tighter.

Switching from a grey to a *renewable energy supplier* is as easy as it gets; fill in your details on the internet and you are done and it doesn't even cost you more. From 2012 on,



Figure 8
Consumer trends

there will be no light bulbs for sale within the European Union; all consumers will just have to go for *energy saving lights* (CFL and LED). *Watson* is an energy monitoring system; indicating how much power your appliances are using by showing a subtle glow that changes colour when you are consuming more or less energy than normal.

e Conversations

There is more and more active engagement of *prosumers* in conversations with brands via the internet.

Now consumers are *tweeting* about their experiences with brands and their products and services, companies can engage in this open discussion. *Tripadvisor* features over 30 million reviews of hotels around the world and is now open towards feedback on the reviews from the management of the hotels. *Method* from San Francisco again; their website is an example of openly starting a discussion with consumers on your corporate website by maintaining a blog with an active community.

Innovation Boom

During the economic recession, smart entrepreneurs enter the market with innovative products for a fair price. The need

to get more value for your money asks for innovative and basic products, which can be oriented towards a niche market. This trend has a contrast with the brand consciousness of global urban citizens.

The *XO laptop* (aka \$100 laptop) inspired all manufacturers to start selling netbooks. *Tata Nano* is the cheapest new car on the planet, making car ownership a reality for a before unattended market of low middle class consumers in developing countries and soon also in developed countries. Inspired by Africans using their prepaid credit as electronic cash, Nokia is launching *NokiaMoney* for payment in stores etc.

Happy ending

Companies have to show their customers they really care about them. This can be realised by personal communication and special care programs, showing empathy in turbulent times.

Nokia offers *free mobile charging spots* in schools and airports all over the world. *Ben & Jerry's* occasionally gives away free icecream to it's customers. Diesel provided visitors of Dutch festival Pinkpop with a *free shower service*.

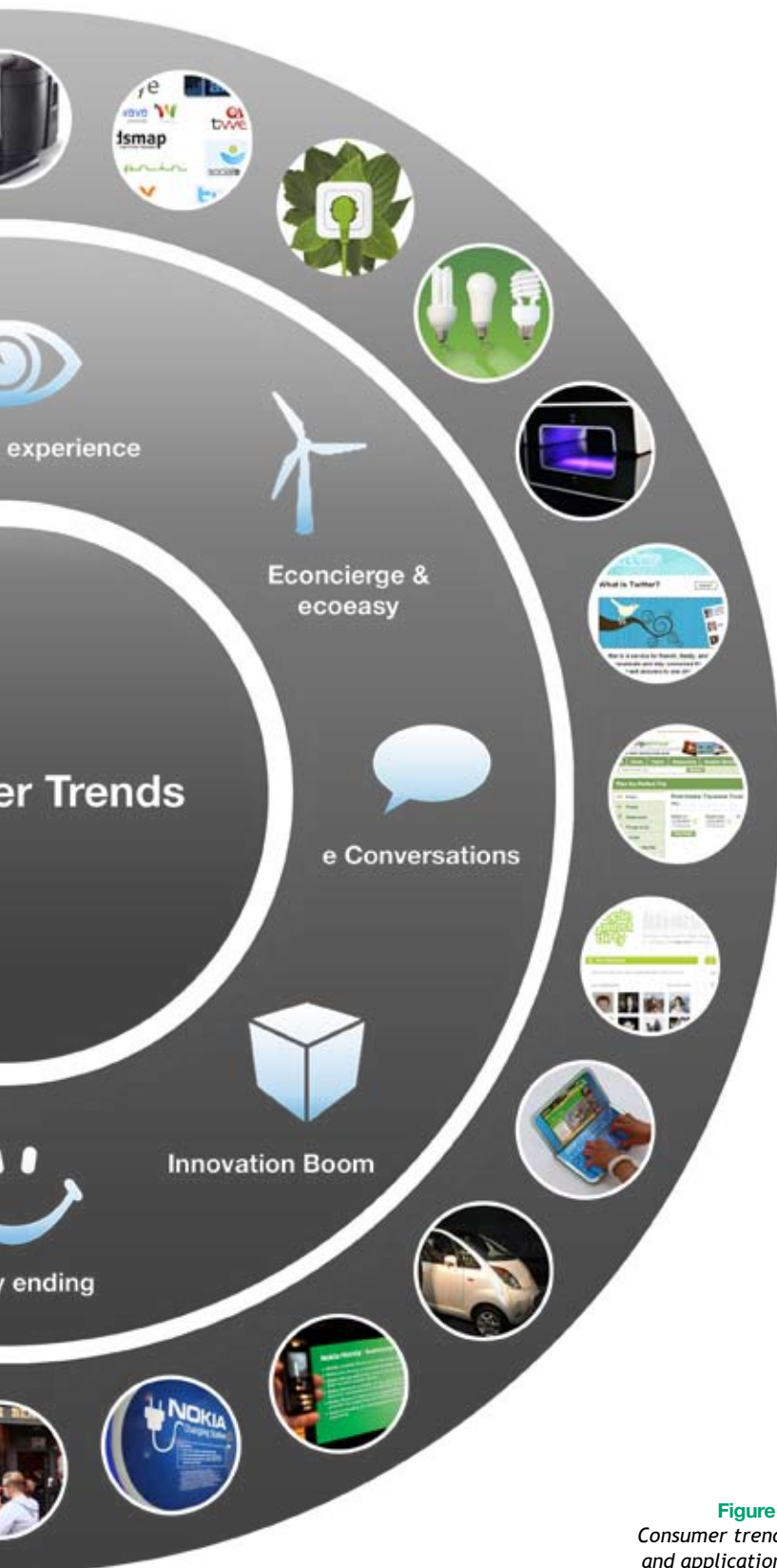

Figure 9
Consumer trends
and applications



Figure 10
Sustainable cities of
the future

4.3 Urbanization and sustainability

Urbanization

Since 2008, more than half of the global population lives in urban areas. In 2030, 60% of the population will live in cities, which means 2 billion new urban citizens. We are building the equivalent of a city the size of Vancouver every week and most of this growth takes place in developing countries, creating so-called mega cities (Robert et al. 2003). The growing group of urban consumers will demand more and more remarkable, daring, innovative and sophisticated goods.

Sustainability

Our society is going through a funnel; we are running out of materials for our products and oil for our energy. We are dealing with human caused global warming because of greenhouse gas emissions and we are deteriorating the earth by extracting the last bits of material and oil we can find underneath its crust. Because we are living in the time of peak oil and peak material, we are paying more and more for the same oil and material. We are either ethically or economically forced to look for options for sustainable living and this trend will only grow as the world will go further into the funnel. It seems hard to get of our addiction, but in the end we will have to switch to *business as unusual*.

Urbanization and sustainability combined result in a future scenario: sustainable (mega) cities of the future.

Megacities are cities with more than 5 million inhabitants. It is estimated that in 2015, there will be 60 of those megacities, together housing more than 600 million people. Two thirds of the megacities will be located in developing countries (UN 2002). There are several challenges related to this future scenario. Each of them is a huge design assignment in itself, with an extensive range of possible solutions.

Urban sustainability challenges to be faced (Kraas 2005):

Waste and pollution

Waste and pollution in cities is mainly generated by households, transport and industries.

Households are the main producers of a city's waste. In developed countries, the collection of waste and either landfilling, burning or the recycling of waste is institutionalised. Waste separation differs between countries: in India, the re-use and recycling of waste is a natural part of product lifecycles since the value of waste is a source of income for individual waste collectors, whereas in Western societies, the value of waste is relatively low. In the United States, household waste is mainly dumped in landfills, which is cheaper than burning or recycling waste. The European Union is stimulating the recycling of waste.

Personal and goods transport produce

emissions, which result in the direct pollution of the local environment (e.g. air quality impacts related to emissions of NO_x, CO and fine particulates (PM), leading to smog, acid rain and negative effects on human health). Secondly, the emissions from transport contribute to climate change. These emissions increase with increasing transport needs.

Some industries (like chemical and heavy metal industries) are producing hazardous waste, however most industrial waste is non toxic. It is a challenge to use the waste from one industry as raw material for another.

Furniture manufacturer **Herman Miller** makes Cradle to Cradle office chairs, according to the philosophy of zero waste. Architecture firm **2012** makes buildings from local waste materials, which they harvest like we did 1000 years ago (and many rural villagers are still doing today). UK based **RecycleBank** offers money to citizens in exchange for waste materials.

Water and energy supply shortages

Water is an essential resource for life and good health. A lack of water to meet daily needs is a reality today for one in three people around the world.

The situation is getting worse as needs for water rise along with population and prosperity growth, urbanization and increases in household and industrial uses (WHO 2009).

With frightening terms like 'Peak Oil' and 'Energy Crisis', energy supply shortage is a big issue for companies, the economy and individuals. Global political instability and the shrinking oil reserves result in rising energy prices and research and development into renewable energy sources.

Local, self-controlled and renewable energy might seem the ideal alternative. A good example is **DonQj**, an urban windmill. Water can be reused several times before dumping it via the sewage system; **grey water** can be used to flush the toilet. **Natural heating and cooling** can reduce home energy use with one

third.

Traffic congestions

Traffic congestions in cities are the result of personal transport (mainly commuting) and inner city goods transport.

People tend to have a strong desire for mobility. Mobility is embedded in our daily lives and has a very high value (in a social, cultural, psychological and economical sense). Our freedom of action is the power to overcome the restrictions on physical movement in space. But, is mobility really the need? Access could be considered as more relevant than mobility. In this sense, it is very arguable to hold video conferences and telework from home, to save the time and environmental impact of travelling to meet or work at an office. Another kind of access can be achieved by building city blocks, which contain all essential functions at a distance which can be travelled walking. These compact cities could function to a certain level as an autarkic area. So, increasing mobility might not be a lasting option in the future, but a switch towards a focus on access to what people need is more essential (Koren et al 2008). In the meanwhile, we also need sustainable innovations on a product level.

The transport of goods should be kept out of the innercity areas where possible and executed in a sustainable manner when transport is really needed.

Teleworking is the perfect solution for reducing commuting traffic, but does it give the same productivity to companies? **Automated Guided Vehicles** (AGV's) could theoretically erase traffic jams (and accidents!) Personal innercity vehicles for rent like presented by **MIT** could make driving a service instead of a product (like owning a car).

Health problems

One of the categories of environmental impact is health impact (Crul et al. 2009). Urbanization is one of the biggest health challenges of the 21st century (WHO 2009).



an example of a stimulus: it supports great African leadership. **KIVA** is an example of a microfinance institution, providing loans via crowdfunding to entrepreneurs in developing countries, dramatically cutting costs in interest rates for those entrepreneurs. **Mobile phones** are amazing tools for every micro and small entrepreneur to access information (eg: the current rate at which their crops are bought).

Social security and public safety problems

A city's citizens have very different geographical origins. This melting pot of different local, national and international cultures can result in an absence of social cohesion, segregation and eventually anonymity on an individual level. The lack of social security can result in public safety problems.

Growing online communities like **MeetUp** are more and more replacing geographical communities by linking people according to their interests. But our houses stay geo-local and **local coaches** can help control the cohesion: both in rich cities in Western countries and in slums in Africa.

Figure 11
Urban sustainability
challenges and
solutions

4.4 Conclusion

The criterium for making the product fit the global urban market, can be split into more specific criteria. Not all these criteria have to be met. For all three main criteria, at least one subcriterium should be met. The subcriteria are intended to serve as inspiration.

Fit the global urban consumer

Status

Authenticity

Fit current consumer trends

Buying the experience

Econcierge & ecoeasy

e Conversations

Innovation Boom

Happy ending

Design-centric

Global citizens

Mapmania

Fit urban sustainability challenges

Waste and pollution

Water and energy supply shortages

Traffic congestions

Health problems

Limited green spaces

Poverty and malnutrition

Social security and public safety problems

5

| | |
|--------------------------------|----|
| 5.1 Introducing a new material | 27 |
| 5.2 Moulded Bamboo Mats | 28 |
| 5.3 Bamboo Fiber Composites | 34 |
| 5.4 Material selection | 37 |
| 5.5 Conclusion | 37 |

New bamboo material

This chapter is about new bamboo materials and the theories behind new material and production commercialisation.

5.1 Introducing a new material

Since the 1990s new bamboo materials such as Plybamboo and Strand Woven Bamboo have become available on the international market. More materials are in development, or are already available on local markets in bamboo producing countries. Different bamboo materials have different properties and can have different fields of application. Appendix 1 gives an overview of bamboo materials, its properties and its applications.

Successful materials on the market have all followed the *new material commercialisation*

process (Van Kesteren and Kandachar 2004). This process is comparable with the famous *diffusion of innovations* theory (Rogers 1995) for new products. Figure 12 shows how the two theories overlap.

According to Rogers' diffusion of innovation theory, trying to quickly convince the masses of a new and controversial idea is useless. It makes more sense to start convincing innovators and the early adopters. Innovators and early adopters can be convinced by introducing a remarkable product (Godin 2003), that is worth talking about.

But being remarkable is not enough, the product should be an enabler application (Musso 2005) to give the commercialisation of the new material a boost. Characteristics of

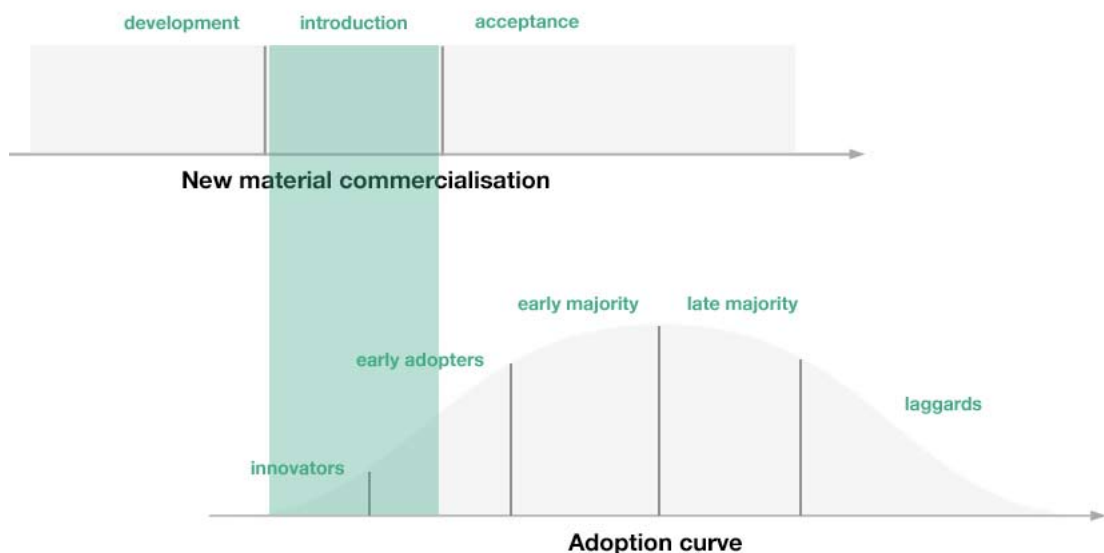

Figure 12
Overlap between
new material
commercialisation
process and
adoption curve

enabler applications:

- Simple value chain
- High fault tolerance
- Small market
- High visibility
- Low material-cost sensitivity
- Provides the material with credibility
- Demonstrates the unique values of the material.

Compared to new product commercialisation, new material commercialisation is usually focussed on a wide range of markets and possible applications, while most products are only focussing on one or a few markets. Economics ultimately dictates the markets that are really interesting for a new material (Williams 2004).

By using the new bamboo material in a remarkable product design, a showcase of the material and its unique properties will be made. An overview of bamboo products that have been featured in magazines and on weblogs (which might be considered a good indicator for being remarkable) is given in appendix 2.

The examples in appendix 2 have some aspects in common:

- Made by a big brand (though not always)
- Well designed
- The use of the material is innovative (never thought of before) and the result is fascinating to look at
- High quality photographs of the product
- A story about for instance sustainability can strengthen the image
- Combined with other materials.

It is difficult to judge whether these products are enabler applications, but they are definitely remarkable.

5.2 Moulded Bamboo Mats

One new bamboo material is Moulded Bamboo Mats. The quality of bamboo mats is the ability to give it any shape you like. Bamboo

mats can be fixed in a mould and glued together to remain in that shape. With this technique, one may construct geometrically complex structures: in one piece, at low cost, low weight and with yet very good mechanical properties.

Bamboo mats are made of woven bamboo slivers. The mats can serve as input for the production of various boards, or can be pressed into moulds of various shapes. In China and India, the mats are used to make for instance corrugated boards, which are used as roofing material (Van der Lugt 2008).

The art of weaving mats is simple and is performed by various rural communities. From split bamboo, the epidermal layer is removed and slivers of thickness ranging from 0.6 to 1.0 mm are made and dried in air to moisture content of around 15%. The dried slivers are manually woven into mats. The mats can be of different sizes and patterns. For creating different aesthetic weaving outputs, it is also possible to use different colors.

For the production of corrugated board, 2 to 5 layers of dry bamboo mats are treated with resin, dried for about 2 hours at 95°C and moulded together by using a hot press and a mould (Qisheng et al. 2003). The hot press and the mould require an industrial production set up. It is also possible to use lay-up moulding.

Resins for MBM products:

- Phenol formaldehyde (PF) is mainly used
- Epoxy is used by Gary Young to manufacture surfboards
- PLA resin is used by Ro Koster and Ad Kil for the design of a coffin. A combination of PLA and bamboo results in a biodegradable composite material. For some durable applications, this is a disadvantage.
- Polyester does not bond to bamboo, as experienced by participants of the Dutch Design Meets Bamboo workshops.

The surface of the final product is not flat, since the mats are not flat. To create a flat

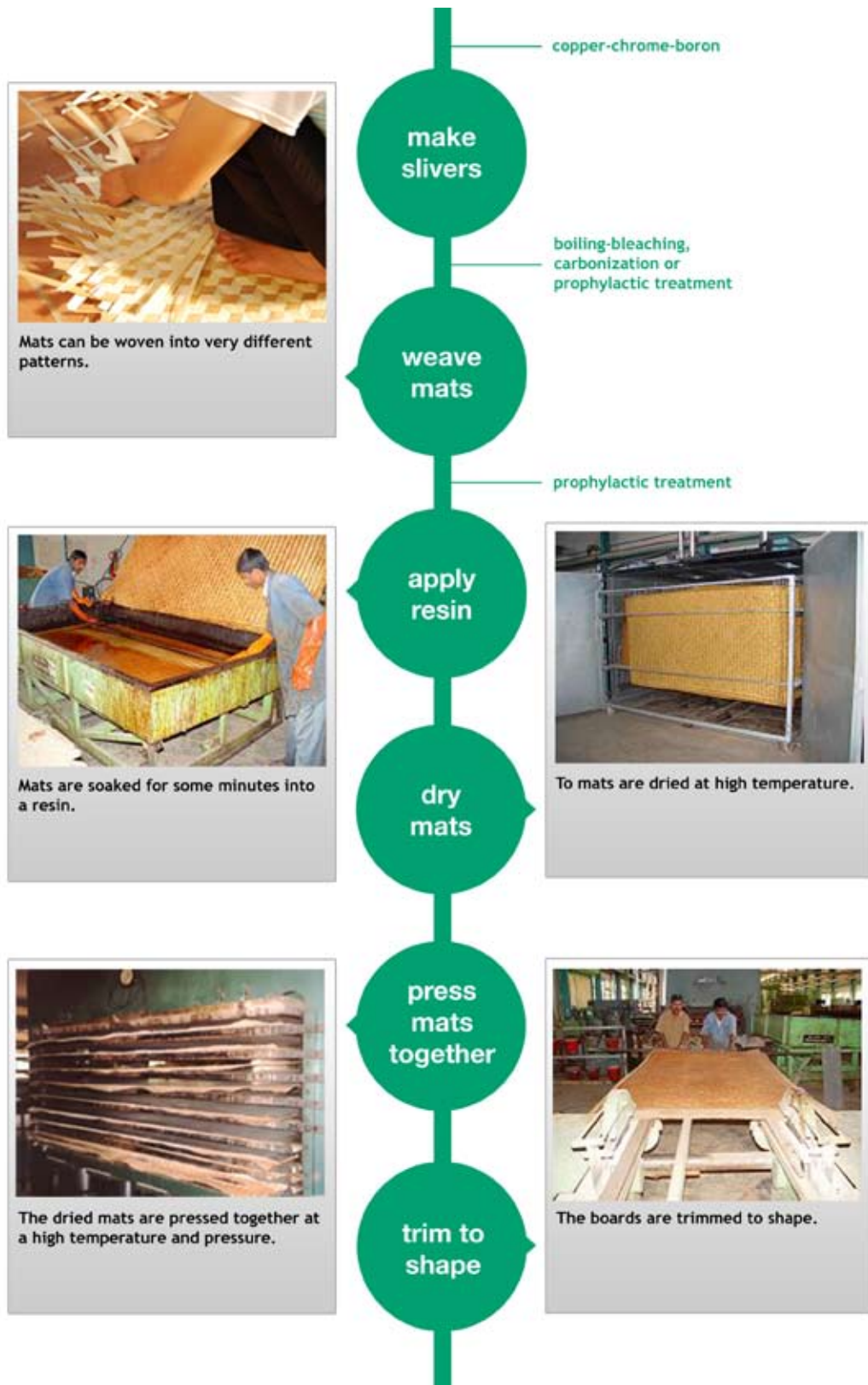

Figure 13
Flowchart of the production process of MBM products and a few possible preservation methods are mentioned right of the flowchart (INBAR)

surface, the final product can be sanded, or a resin can be used to function as a coating.

Extruded Polystyrene (XPS) foam can be used to fill a hollow structure and create more stiffness.

Variables in production of products from MBM are:

- Thickness of the bamboo (the thickness has to be uniform)
- Slivers used to weave the mats (dimensions and fiber density)
- Glue characteristics
- Moisture content
- Pressing parameters
- Drying temperature of the resin-treated mats

Bamboo mats can also be glued on plywood, to make a rigid material with the looks of MBM, without using an industrial set up.

MBM has unique qualities, which make it an interesting material for application in different fields.

Advantages of MBM (Qisheng et al. 2003 and INBAR):

- Lightweight
- Flexibility of mats results in lots of possible shapes
- Good impact resistance
- Aesthetics (natural appearance)
- Resistancy to boiling water, weather and biological agencies (insects and fungal attacks) comparable with waterproof plywood
- High scratch and stain resistancy
- Fire resistancy comparable with fire-retardant treated plywood
- Reduced dependence on wood, which has a lower yield than bamboo
- Creation of employment opportunities in mat weaving, particularly for rural and tribal people.

Disadvantages of MBM:

- Use of a toxic resin is harmful to the environment.
- (Semi-) industrial set up which results in less possibilities for input from craftsmen in the next step of the production process.

- Non-uniform bonding due to inadequacy, or even absence, of resin on slivers in the overlapped areas of mats.
- Limited durability.
- High quantity of resin required (1.3 kg/m²) as compared with that for plywood (0.3 to 0.33 kg/m²).

A specific type of MBM is Bamboo Mat Board (BMB). BMB can be used as construction material to build walls for housing, or it can be used as decorative material to cover surfaces. BMB has the potential to become the next high quality bamboo panel material.

Bamboo Mat Boards are a substitute for:

- Thin plywood
- PVC panels
- Metal sheets
- Gypsum panels
- Asbestos panels

BMB is however not very price competitive; the retail price of BMB (source: personal communication with retailer MatKing) is roughly six times the retail price of plywood (source: personal communication with carpenter). The production costs of BMB (IPIRTI) are half the retail price of plywood.



Figure 14
Corrugated boards
(used for roofing)
by IPIRTI

Figure 15
Closet from bamboo
mats on plywood by
MP Ranjan

Figure 16
Chair by Maarten
Baptist for Dutch
Design Meets
Bamboo

Figure 17
IPIRTI house



Figure 18
Helmet by Roof

Figure 19
Padle by Gary Young

Figure 20
Plate by Nicolas Cortolezzis for IKEA PS series

Figure 21
Surfboard, filled with XPS foam by Gary Young

5.3 Bamboo Fiber Composites

Bamboo Fiber Composites (BFC) can be compared with carbon and glass fiber composites and are also known as the *natural glass fiber*. The composite exists of bamboo fibers and a polymer. The material has even more geometrical possibilities and better mechanical properties than MBM. The costs are however higher and the manufacturing process is more industrial.

Bamboo fibers are extracted from raw bamboo, by separating the cellulose fibers from all other particles (see figure 22).

There are different methods to extract the fibers:

- Chemical (hydrolysis alkalization): Sodium hydroxide is used to cook crushed bamboo into a form of regenerated cellulose fiber. Carbon disulfide is used for hydrolysis alkalization combined with multi phase bleaching (Beijing University)
- Biological: Crushed bamboo is treated with enzymes to break the bamboo into a mushy mass and individual fibers are cumbed out (Beijing University)
- Steam explosion (Okubo et al. 2004)

Research is being performed on optimizing the separation process by for instance rubbing the remaining lignin of the fibers (Okubo et al. 2004).

The fibers can be woven into a mat, or the fibers can be placed in random directions.

The fibers can reinforce thermoplastics to increase tensile strength. The tensile strength of bamboo fibers can be compared that of jute. It is also possible to combine bamboo fibers with a resin or PLA. For some durable applications, the disadvantage of using PLA is the fact that it is biodegradable.

The figures on page 36 give an overview of products from bamboo fiber reinforced materials.

Advantages of BFC (Jain et al. 1992):

- High tensile and impact strength; around 80% of glass reinforced composites (Dieu et al. 2004).
- Lower density than glass and carbon reinforced composites.
- Lower production costs and less energy needed for production than glass and carbon reinforced composites.

Disadvantage of BFC:

- Industrial and high tech set up which leaves little input for craftsmen.

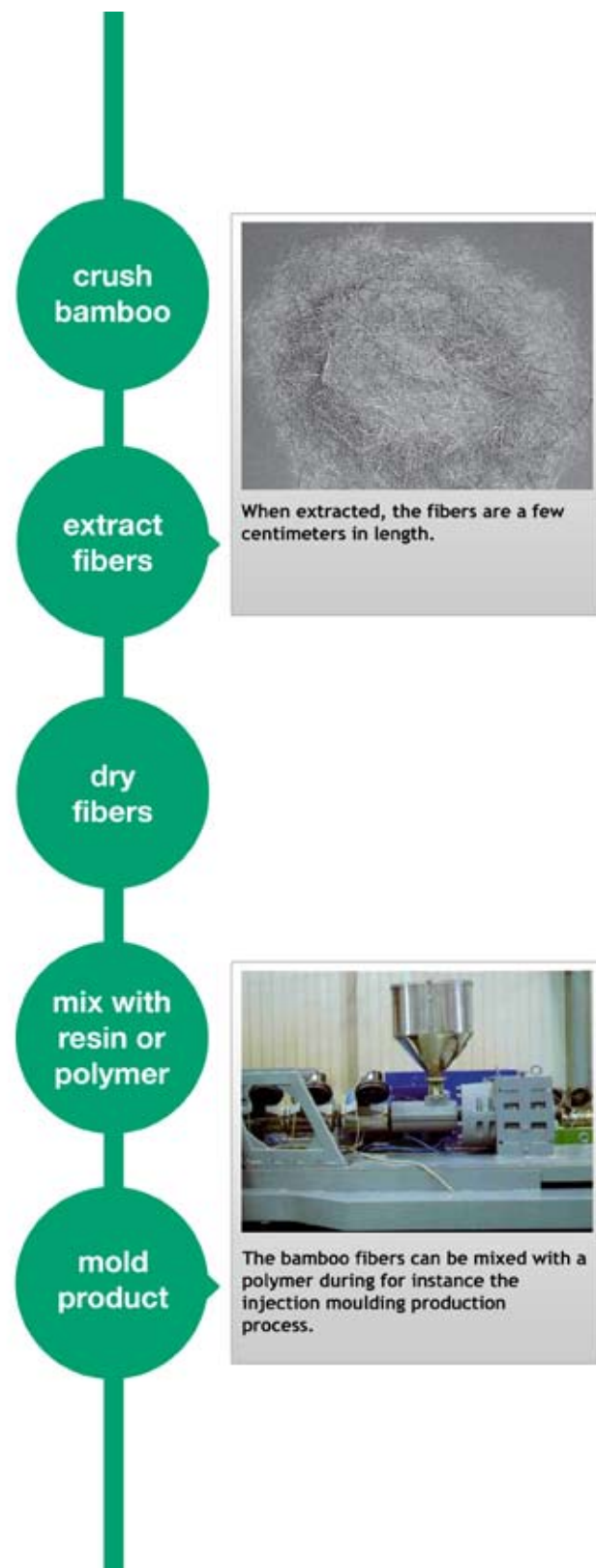

Figure 22
Flowchart of the production process of BFC products (Okubo et al. 2004)



Figure 23
Bamboo Composite Road Frame
Bicycle frame by Brano Meres

Figure 24
Mitsubishi car doors
Mitsubishi is developing bamboo fiber fortified car doors

Figure 25
Speakers by Panasonic
Carspreakers by Panasonic and Doshisha University

Figure 26
Bamtrike
Tricycle by Alexander Vittouris

5.4 Material selection

Solely based on the argument of social equitability and job creation opportunities, Moulded Bamboo Mats is the most viable material of the two.

Bamboo Fiber Composite is an interesting material, because it combines high tech with sustainability. However it does not fit the starting points of this thesis.

To get more insight into the selected material, the semi-industrial production of MBM products is further explained in appendix 3.

The resin which is used for MBM makes it potentially unsustainable material, unless bioresin is used. Biological adhesives have been used for ages, but after the industrialisation, synthetic alternatives have proven to be more effective. However, there are some recent developments in the field of natural bioresins (Netravali 2003), like PureBond, which is a soybased adhesive used in the plywood industry. PureBond works like the adhesive material mussels use to colonize surfaces (Graham 2008). MBM combined with a bioresin is called a biocomposite.

5.5 Conclusion

This chapter resulted in new criteria:

| |
|------------------------------------------------|
| Remarkability |
| Remarkable |
| Simple value chain |
| High fault tolerance |
| Small market |
| High visibility |
| Low material-cost sensitivity |
| Provides the material with credibility |
| Demonstrates the unique values of the material |

6

| | |
|------------------|----|
| 6.1 Kotwalia | 39 |
| 6.2 Field visits | 39 |
| 6.3 Value chain | 48 |
| 6.4 Conclusion | 48 |

Kotwalia community

This chapter is about the tribal craftsmen; the producers of the product. The chapter is based on literature research, discussions with experts and a workshop in the field.

6.1 Kotwalia

The target producers are tribal craftsmen from rural communities in India. The Kotwalia community in southern Gujarat is used as an example of a rural community of poor bamboo craftsmen. The Kotwalia community is one of India's *primitive tribal communities*. The community is especially famous for its weaving. Bamboo craftsmanship is the primary source of income for the Kotwalia tribals. All their products are made with help of simple tools (sickle, axe and knife). For more insight into the culture of the Kotwalia community, see appendix 7.

The products that are currently being produced by tribal craftsmen don't fit the needs of the global urban market, due to the following reasons:

- Low quality (and too much variation in quality).
- Low production capacity (and unreliable capacity).
- Aesthetics of bamboo products don't fit the market.
- Use of toxic materials for preservation and gluing that are not allowed on the market and a high environmental burden of transport.

These challenges have to be overcome, to make a successful product for the global urban market.

The production of bamboo products is decreasing, because:

- Low availability of the material (the bamboo forests are government controlled).
- Low profit rates (middlemen, low value products).
- Competition from cheaper plastic products.
- Lack of standardisation.
- No connection with the high end market and no knowledge about technological developments and thus a lack of innovation (source: Tribal Development Department, Government of Gujarat, India).

6.2 Field visits

To get insight into the production process and skills, a 4-day workshop is organized in the Kotwalia community during which skilled craftsmen produced all types of products to showcase their abilities. Four products that were made during the workshop are shown on pages 42 and 43. For more products, see appendix 6. An overview of used techniques is given on page 44 and 45. For more insight into the workshop, see appendix 6.

The products that are made during the workshop are made manually and with the use of simple hand tools. To improve the quality of production, a semi-industrial set up is being introduced by several organisations. Direct effects of semi-industrial production are:

- Large workforce producing a limited number of standardised products.
- Specialisation of tasks and skills for craftsmen.

-
- Long term and stable income generation for craftsmen.

The capital and market insights, required for starting semi-industrial production, are generally supplied by the government (or a government sponsored organisation). This means that the craftsmen are generally not 'in charge' of the organisation, which keeps them in a vulnerable position.

The Forest Department of Gujarat and CIBART are both organising a semi-industrial production centre in southern Gujarat, employing Kotwalia craftsmen.

The Forest Department controls a workshop centre, where simple hot pressed bamboo products are being made from bamboo mats. The mats are made by the Kotwalia community and sold for Rs 10 (0.17 euro) each to the Forest Department. A complete overview of the production process is given on page 46 and 47.

CIBART just started with the production of furniture at a workshop centre in Ukai. CIBART has also built a capital intensive treatment plant and nursery. For more insights, see appendix 8.



Figure 27
Krukali
A basket, used for storing rice (costs: Rs 30)



Figure 28
Handi
A basket, used for storing fish (costs: Rs 25)



Figure 29

Rangali

A basket, used during marriage ceremony (costs: Rs 101)

Figure 30

Sabadi

A plate, used for serving roti (costs: Rs 10)



Bamboo culms are split by using a simple axe.



Sliver making is done with only a machete knife as tool. Tribal craftsmen are very skilled in this labour intensive work.



The craftsmen make three types of slivers. For mat weaving, *banh* is used. *Banh* is a thin and clean sliver with high flexibility.



The second type of sliver is called *paat*. *Paat* is used for the construction of baskets.



The third type of sliver is called *hilly*, which is used to fill the *paat* based construction of a basket.



For weaving baskets, the slivers are sprinkled with water to make them flexible.



Figure 31
Tools and techniques



Bamboo culms are split by using a simple axe.

split
culms



Sliver making is done with only a machete knife as tool. Tribal craftsmen are very skilled in this labour intensive work.

make
slivers



Mats can be woven into very different patterns. The commonly used pattern is the herringbone.

weave
mats



To make the resin, phenol, formaldehyde and sodiumhydroxide are mixed and heated up to 90/95 degrees Celsius. Sodiumhydroxide is used as catalyst.

make
resin



Mats are soaked for some minutes into the PF resin.

apply
resin



The mats are dried for 5 days; half a day in the sun and the rest of the time in the shadow.

dry
mats



Figure 32
Production of MBM products

6.3 Value chain

The craftsmen are very dependent on directly linked value chain players: the government and middlemen. The government is the only or main material supplier towards the Kotwalia community and the supply is very limited and uncertain. When the government doesn't supply bamboo stems, the craftsmen have to steal bamboo from the forest, which is a dangerous job. An alternative is to buy bamboo from growers at a price of Rs 15 to Rs 50 per stem.

Middlemen are paying the craftsmen low prices, which is the reason the craft is slowly disappearing. An average salary for a household that is depending on bamboo crafts is less than Rs 100 (1.70 euro) per day. The selling price for several bamboo products that are produced by the Kotwalia community, are given in appendix 6.

There are several strategies to improve the position of the craftsmen and to make them less dependent:

- Support the craftsmen to grow their own bamboo.
- Give the craftsmen access to tools or a workshop.
- Give the craftsmen access to preservation methods.
- Supply the craftsmen with education to improve their skills and market insights.

6.4 Conclusion

The criterium for making the product fit the tribal producers, can be split into several criteria.

Value of the product for the craftsmen

Profit generated with the product

Relative profit for the craftsmen

Technology level needed for production

Level of standardisation and quality

Complexity of the product and production

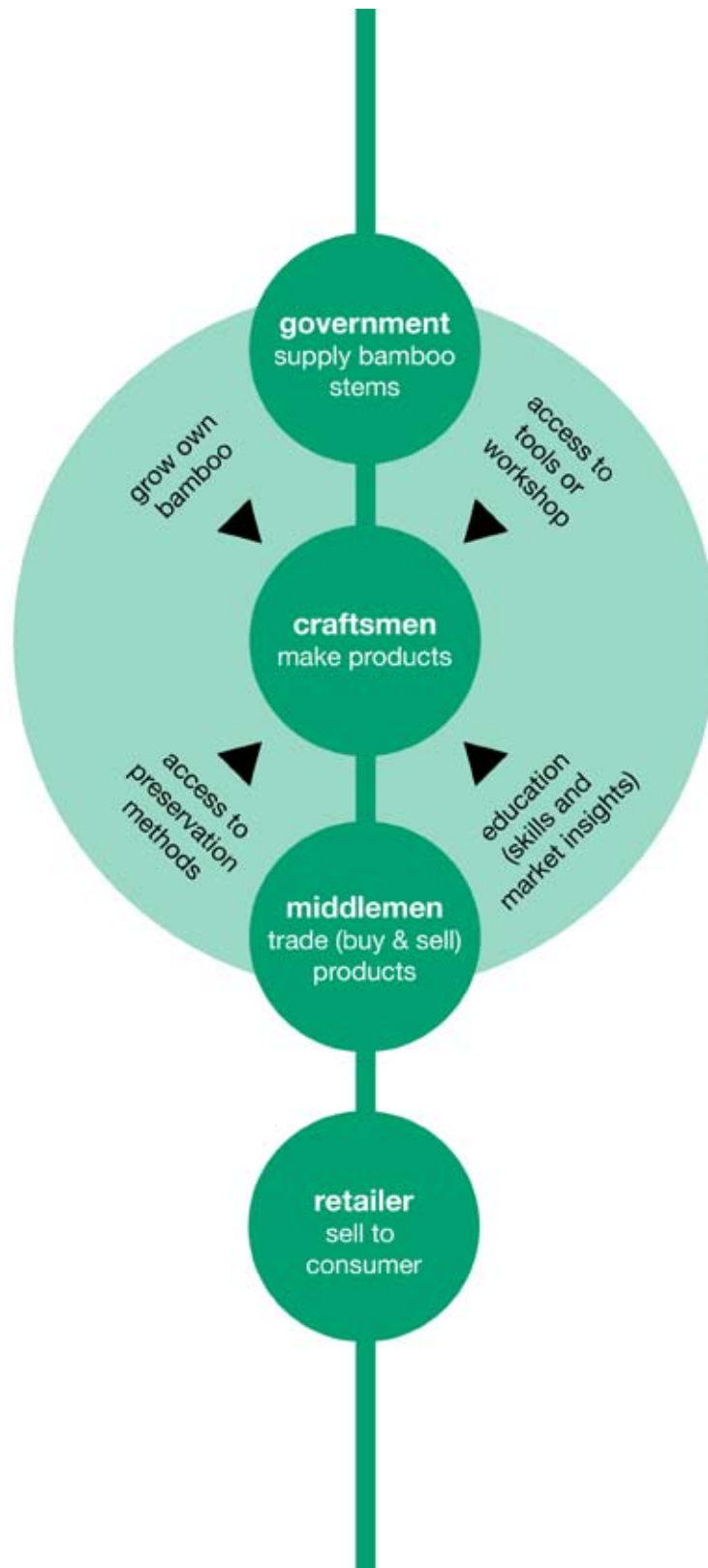

Figure 33
Value chain of the production of bamboo crafts products.

7

| | |
|-----------------------|----|
| 7.1 Benchmark | 51 |
| 7.2 Creative sessions | 56 |
| 7.3 Idea selection | 58 |

Applications

A variety of products can be made from moulded and pressed bamboo mats. A benchmark of products from comparable materials is made and two creative sessions (one with students and a second with designers with experience with bamboo) are organized.

7.1 Benchmark

For inspiration, a benchmark of products from the following comparable materials is made:

- Bendable plywood
- Carbon fiber reinforced plastics (CFRP)

See the next pages for an overview of products. In relation to the profitability and technology level, the products are roughly scored on the two criteria from the previous chapter:

- The value of the product for the craftsmen.
- The technology level needed for production.

Bendable plywood

Bendable plywood is mainly used for furniture applications and has quite a tradition for application in chairs. Other notable applications include a leg prosthesis and the forgotten application of plywood in the structure of airplanes.

Differentiation is mainly found through design aesthetics and not in innovative functionalities.

All these products could be made from MBM, because the bamboo mats are more flexible than the bendable plywood.

value of product



technology level (for production)

Carbon fiber reinforced plastics (CFRP)

CFRP is used for high tech and sports applications. Compared to the products from bent plywood, these products are in any case more 'extreme', which fits good with the image that CFRP has and gives to products.

While bent plywood is just another material, CFRP communicates high tech innovation. The products in the lower left corner of the matrix, seem quite stupid; low value products from an expensive and high value material.

Better applications are: casings for Apple products, safety and the aforementioned sports products.

CFRP is more flexible than MBM, so not all of these products could be made from MBM.

value of product

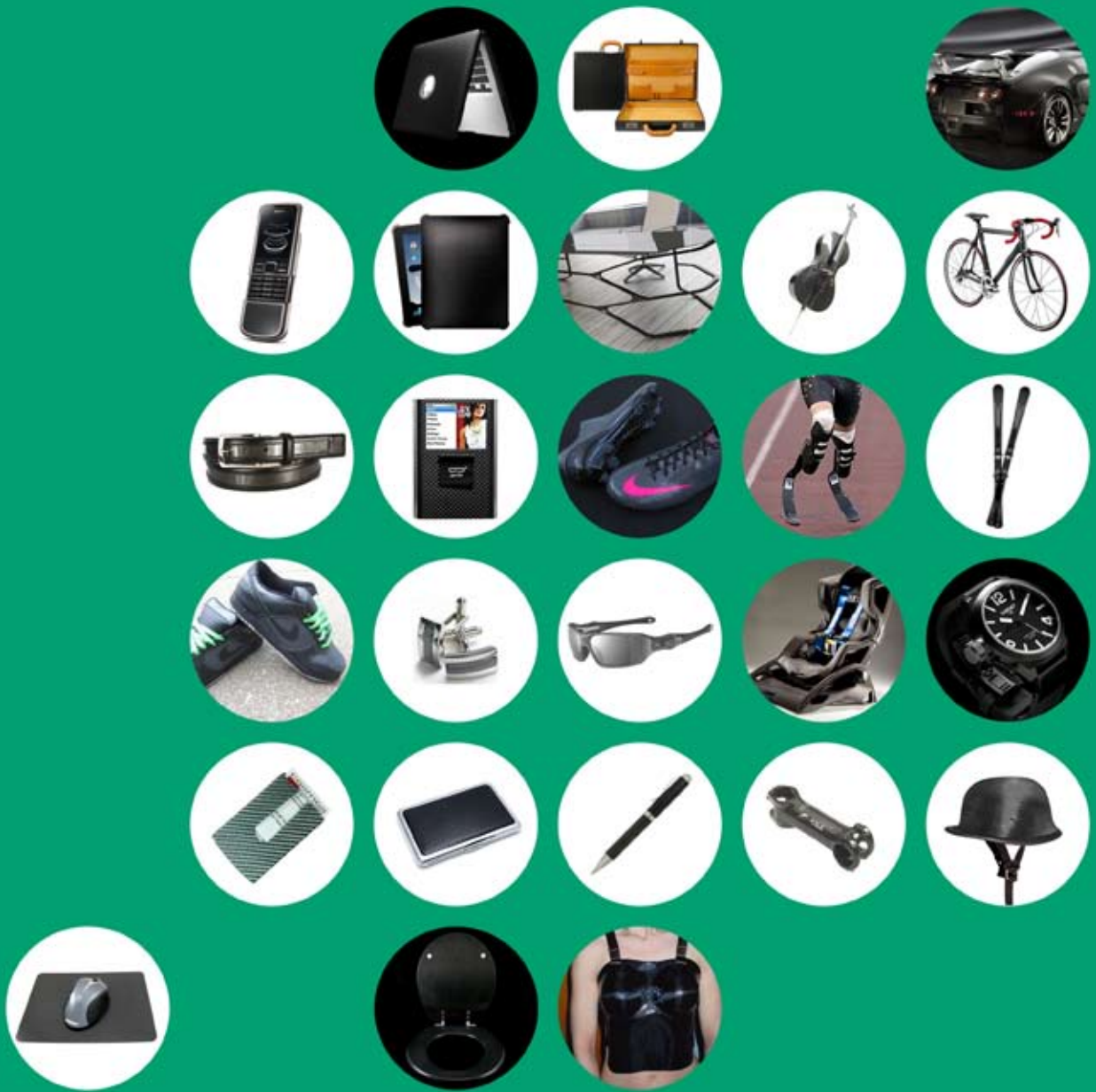

technology level (for production)

7.2 Creative sessions

Two creative sessions are organized to generate ideas for possible applications of MBM. Appendix 4 and 5 contain a report of both sessions.

The most interesting ideas from both sessions and more are scored on:

- The value of the product for the craftsmen.
- The technology level needed for production.

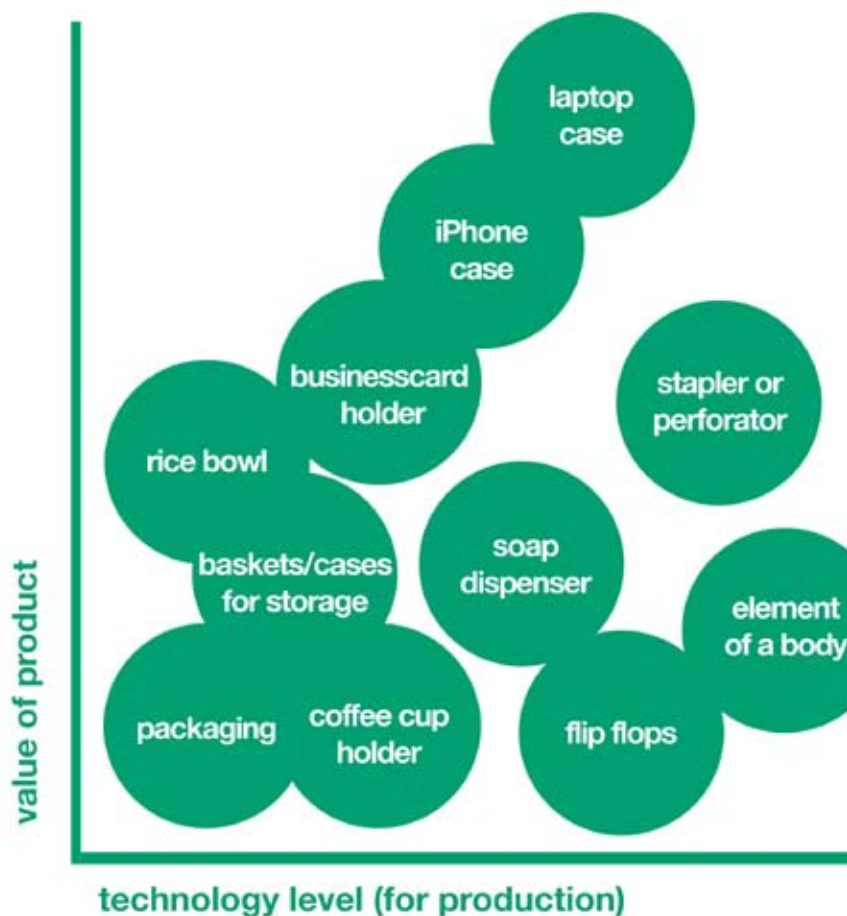

Figure 36
Ideas from the
creative sessions,
roughly scored on
two criteria



7.3 Idea selection

To get a selection of the ideas with the highest potential, all ideas are scored on the following criteria:

- Value of the product for the craftsmen
- Technology level needed for production
- Sustainability
- Remarkability
- Fit the urban consumer
- Commercial potential for me as an entrepreneur

The criteria are aimed at selecting a high potential buzz product that fit the needs of the user and bring profits to the craftsmen and the entrepreneur

For a complete overview of the scores of all ideas, see appendix 10.

The three ideas with the highest potential are:

- iPhone cover
- Wing for urban windmill
- Furniture





| | |
|-----------------------------|----|
| 8.1 iPhone cover | 61 |
| 8.2 Wing for urban windmill | 63 |
| 8.3 Furniture | 65 |
| 8.4 Best concept | 66 |

Concepts

The three selected ideas are transformed into concepts, after which the best concept is chosen.

7.1 iPhone cover

“An innovative fashion item”

The iPhone is the new gadget of our time; the ultimate mobile phone, because of its design and functionality. By the end of 2009, Apple sold 100 million iPhones globally. The iPhone and iPod accessory market was estimated to be \$2 billion in 2009.

There are three types of iPhone cases:

- Sleeve
- Hard case
- Book case

For an overview of existing iPhone cases, see appendix 11.

The selling price for iPhone cases is quite high, because it protects what's precious: an iPhone which costs over €500 and is very dear to its owner. An iPhone case from MBM could be sold to the customer for around \$90 (€60). Online sales is the most obvious choice for this product, since it is really a niche product, which retail shops won't want to keep in stock and since iPhone users are very internet savvy, online sales simply works for them.

To create more buzz around the product and to strengthen its online presence, a crowdfunding campaign could be organized, through which a large group of future consumers invests small amounts of money to finance the production of the case. In exchange for their contribution they get insight into the production and if they contribute for instance \$100, they can pre-order the product.

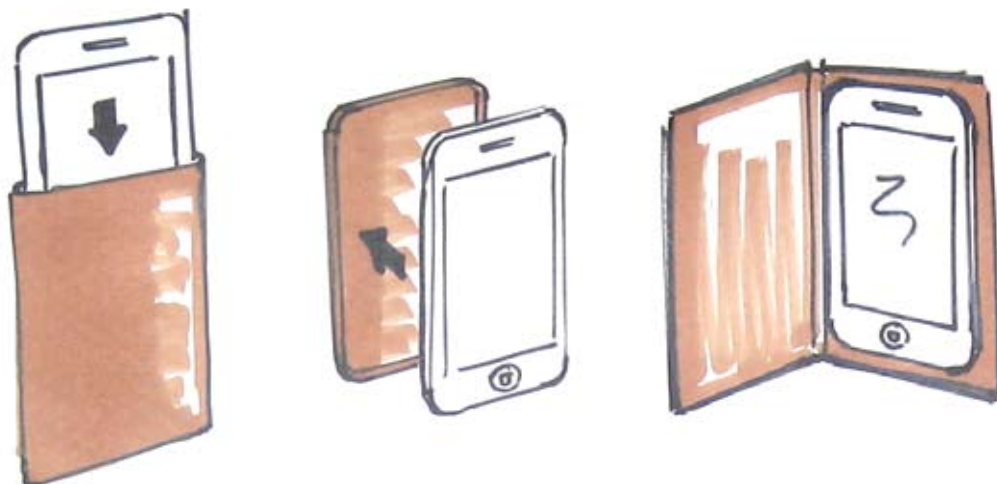

Figure 37
Different types of
iPhone cases: sleeve,
hard case and book
case

In addition to this physical product, an iPhone application about bamboo could be developed, to create an experience (show for instance the life cycle of the product), or to communicate for instance the possibilities of bamboo products and its environmental impact compared to other products. The application should be a real eye-candy to make sure consumers would like to download it.

Future product diversification could include casings for other Apple products like iPods and laptops.

USPs

- Sustainable and innovative fashion item.
- Crowdfunding connects the consumers with the craftsmen and secures sales.
- iPhone application explains the story behind the product.
- Global urban niche market.
- Experience and connections in iPhone (application) market.

Challenge

- Strong competition and need for marketing.

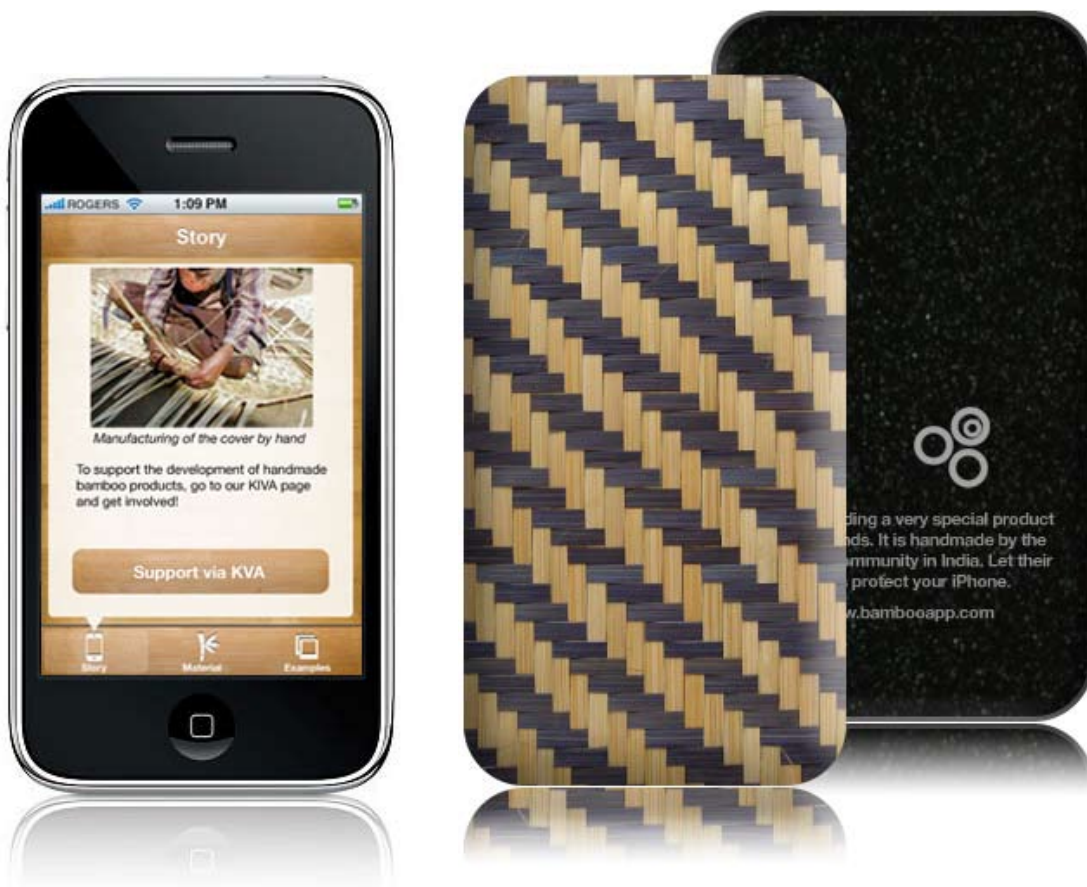

Figure 38
iPhone app, explaining the manufacturing process of the case, bamboo as a material and other products from bamboo.

Figure 39
Outside (from bamboo mats) and inside (from leather, with story about the production) of a case

7.2 Wing for urban windmill “Creating a green image”

Urban windmills are defined as turbines that are specially designed for the built environment, and can be located on buildings or next to buildings. This implies that the turbine has been adapted for the wind regime in the built environment and can, in theory at least, resist wind gusts and turbulences. The shape and size of the turbine have been designed to visually integrate with the surrounding buildings. The capacity of these turbines is generally between 1 and 20 kW. Compared with large windmills, urban windmills generate relatively less energy and are relatively more expensive. This is due to the smaller size of the windmill and the location of installation (Jadranka 2007).

There are different types of urban windmills. They can be generally categorized as horizontal axis and vertical axis windmills.

For an overview of urban windmills, see appendix 12.

The selling price of an urban windmill from MBM could vary a lot; it depends on aspects like:

- Size (and power)
- Cost of electrical components
- Cost of materials and manufacturing
- Target consumer group (and intention to make a profit or not)
- Volume of production

A windmill, designed for urban use, might also be used in rural surroundings. In rural surroundings, the windmill, could for instance be used to generate electricity, or as power source for an irrigation system.

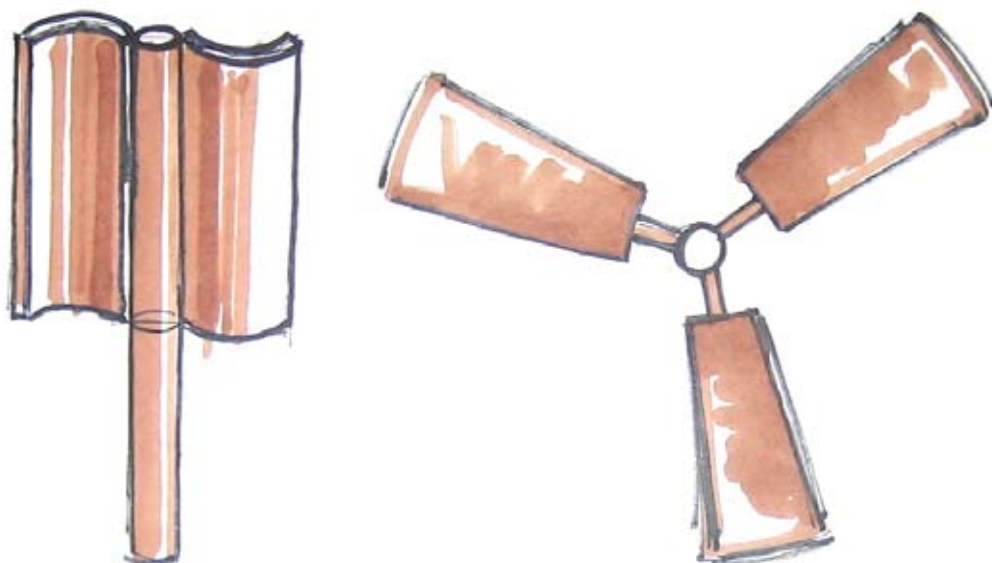

Figure 40
A vertical and a
horizontal axis
wind turbine

An urban windmill is more a tool for creating awareness about the environment and renewable energy, then an efficient and high potential source of electricity. An urban windmill is simply a tool for organizations, to show its environmental consciousness. In the Netherlands, urban windmills are mainly installed at important government and company buildings (eg: city halls, corporate head offices, educational institutes, etc.) (Jadranka 2007).

At Cambridge University, researchers have explored the potential of bamboo as a material for making windmill wings (with camber, torque, taper, varying thickness, curvature, etc.) (Platts 2006). Bamboo veneer may be combined with mats for high-quality coating and finishing purposes.

USPs

- Awareness creation.
- A sustainable product from a sustainable material.
- A product in a growing market for renewable energy (and rising energy prices).
- Potential for promotional activities.

Challenges

- A complex and high-tech product.
- Expensive parts (motor, controlling and batteries).
- Water resistancy.



Figure 41
Urban windmill
donQi used for
promotional
activities

7.3 Furniture

To get better grip on the broad concept of furniture, it is (for now) narrowed down to a chair. A chair is a classic object for designers. There will always be a market for chairs and there are thousands and thousands designs available and there is a lot more to discover.

A chair is an ideal product for applying details like:

- Partly treat the mats with resin, to get a product that is partly hard, partly flexible.
- Use 3D weaving, to be able to make more extreme shapes.
- Customization by remelting and reshaping a product at home.
- Use different coloured bamboo slivers and open weaving patterns.

- Add an electricity wire directly into the weaving.
- Add a signature of the craftsman to every product.
- Make smoke patterns on the product.
- Partly burn the material to create a pattern, or a logo.

USPs

- Timeless product.
- Variations are endless.

Challenges

- Not very innovative.
- International transport has a high environmental impact and is dubious for chairs, which are being manufactured on all continents.

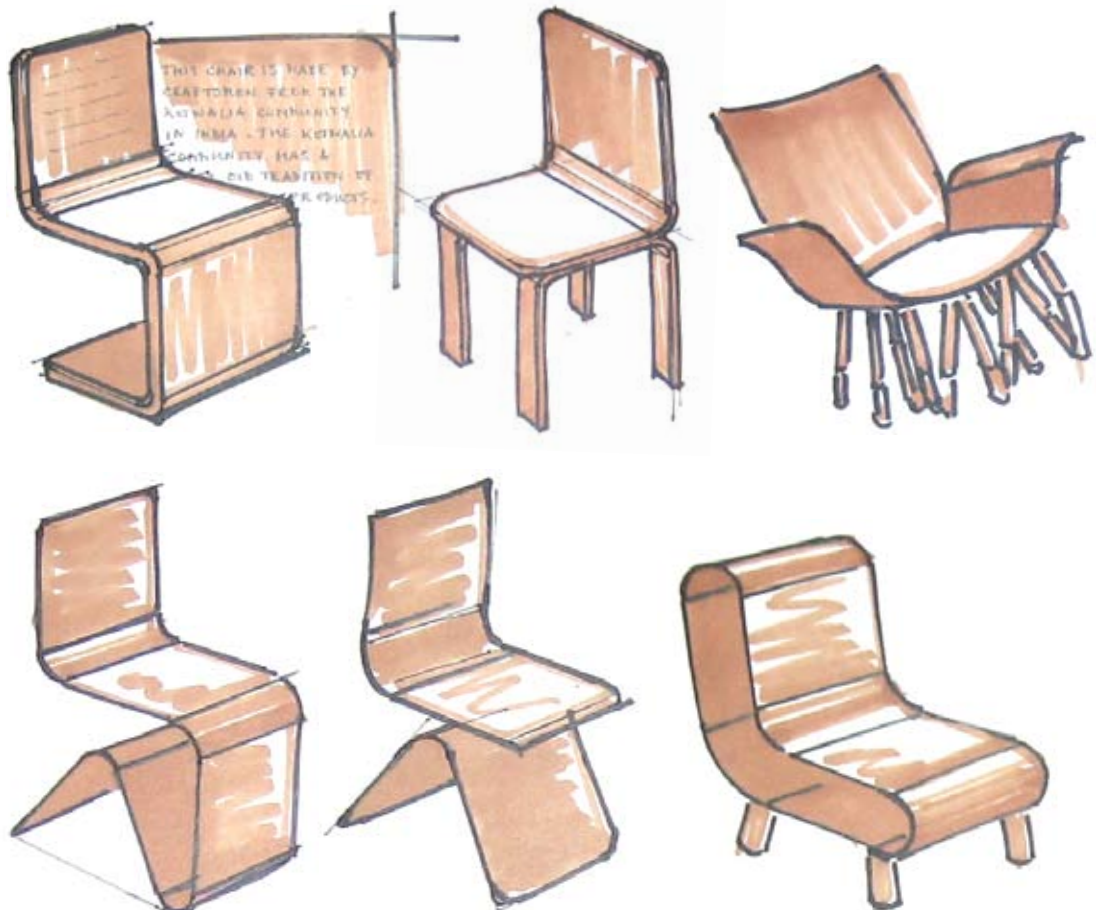

Figure 42
Several chairs

7.4 Best concept

The three concepts are scored on a list of criteria to select the concept with the highest potential. The chair is clearly the least interesting product. For the iPhone cover and the wing for an urban windmill it's a close call. The best concept is the wing for an urban windmill.

| | iPhone cover | Wing windmill | Chair |
|------------------------------------------------|--------------|---------------|-------|
| Value of the product for the craftsmen | | | |
| Profit generated with the product | + | + | 0 |
| Relative profit for the craftsmen | + | 0 | 0 |
| Technology level needed for production | | | |
| Level of standardisation and quality | - | - | 0 |
| Complexity of the product and production | + | - | 0 |
| Sustainability | | | |
| Ecologically sustainable | 0 | ++ | 0 |
| Socially sustainable | + | 0 | 0 |
| Fit urban sustainability challenges | | | |
| Waste and pollution | - | 0 | 0 |
| Water and energy supply shortages | 0 | ++ | 0 |
| Traffic congestions | 0 | 0 | 0 |
| Health problems | 0 | + | 0 |
| Limited green spaces | 0 | 0 | 0 |
| Poverty and malnutrition | 0 | 0 | 0 |
| Social security and public safety problems | 0 | 0 | 0 |
| Remarkability | | | |
| Remarkable | + | ++ | - |
| Simple value chain | + | - | 0 |
| High fault tolerance | - | - | 0 |
| Small market | + | + | - |
| High visibility | 0 | + | - |
| Low material-cost sensitivity | + | - | -- |
| Provides the material with credibility | + | ++ | + |
| Demonstrates the unique values of the material | - | ++ | + |

| | iPhone cover | Wing windmill | Chair |
|-------------------------------------------------------|--------------|---------------|-------|
| Fit the global urban consumer | | | |
| Status | ++ | + | + |
| Authenticity | + | ++ | + |
| Fit current consumer trends | | | |
| Buying the experience | ++ | 0 | 0 |
| Econcierge & ecoeasy | 0 | ++ | - |
| e Conversations | 0 | 0 | 0 |
| Innovation Boom | - | + | - |
| Happy ending | 0 | 0 | 0 |
| Design-centric | + | 0 | + |
| Global citizens | ++ | + | - |
| Mapmania | + | 0 | 0 |
| Commercial potential for me as an entrepreneur | | | |
| Profitability | ++ | + | 0 |
| Existing connections and knowledge in market | ++ | + | - |

An urban windmill aspires to the authenticity of the global urban consumer and fits best with the sustainability targets. An urban windmill has the potential to create awareness for renewable energy and bamboo. The innovative application of the material is another reason to select the wing for an urban windmill as winner.

The complexity of the product, the high price of other components and the lower relative profit for the craftsmen are important challenges for this concept.



| | |
|----------------------------|----|
| 9.1 Introduction | 69 |
| 9.2 Bosman windmill | 69 |
| 9.3 Bamboo wings | 69 |
| 9.4 Design recommendations | 73 |

Wing for an urban (?) windmill

This chapter gives a short introduction into windmills and wind energy and presents the Bosman windmill and new bamboo wings for this windmill.

9.1 Introduction

Windmills produce mechanical power, which can be converted into electricity, or used directly; for instance for pumping water.

At the end of 2009, 2% of the world's electricity was generated by windmills. Almost all windmills are centralised in wind harvesting parks. Urban wind mills are contrary to this, a decentralised source of energy.

Urban areas are generally less rich in wind than rural areas. The Kotwalia community and other bamboo craftsmen are living in the rural parts of India. Only 44% of the rural households in India have access to electricity (Modi 2005), so there is a huge potential to also supply wind energy for rural areas. Appendix 13 gives an introduction to wind energy in India.

The horizontal axis wind turbine has the highest efficiency and seems the best choice. Simplicity is essential to make this product successful. Most urban windmills are very fancy, high-tech products, which is in contrast with the need to keep the product (or at least the wings) as simple as possible to be able to get the wings produced by tribal craftsmen.

9.2 Bosman windmill

The Dutch polders are since 1929 decorated with Bosman windmills. The simple and functional design is very similar to classic American windmills and to current windmills built in Africa and other developing countries. The Bosman windmills have a life expectancy of 25 years, but most last over 40 years. The design of the windmill didn't change much between 1929 and now and has gone through the test of time. The output of the windmill is comparable to the output of the Energyball, which has an output of 500W (see appendix 12).

The wings of the Bosman windmill are used as a basis to showcase to potential of MBM. Although the Bosman windmill is traditionally not a product for urban areas, this classic windmill has the potential to be positioned in new markets from urban areas in the West to rural areas in India.

Technical drawings of the Bosman windmill can be found in appendix 14.

9.3 Bamboo wings

The wings can be constructed from several layers of mats and, based on the original design, a bamboo stem can be placed behind the wing for stiffness. The yield strength of the used bamboo is tested and is around 120 MPa (see appendix 16 for details), which is low compared to for instance 400+MPa for steel.



Figure 43
Installing bamboo wings on a Bosman windmill

To calculate the design dimensions to resist the working load of the wind, a Working Stress Design (WSD) analysis is executed. At a windspeed of 20 m/s (the maximum operational windspeed of the Bosman windmill), the dimensions for the bamboo wings are comparable to the dimensions that are currently used for the steel wings. However, the steel wings can still withstand a higher windspeed. See appendix 15 for the WSD calculations.

The figure on the left shows how the bamboo wings are being installed on a 4 meter high Bosman windmill that is owned by Rabobank Hoeksche Waard. The wings will be installed for three months, to analyze the durability.

See appendix 17 for insights into the building of the prototype.



Figure 44
*Bamboo wings on a
Bosman windmill*



Figure 45
Bamboo wings on a
Bosman windmill

9.4 Design recommendations

For this project, the design of an existing windmill is chosen to showcase the possibilities of MBM by replacing the metal wings by bamboo wings. Although the showcase is successful, a new windmill could be designed to create an even more remarkable product.

For the new design, the shape of the wings could be optimized for efficiency and the construction could be optimized for use in urban areas. Figure 46 gives an impression of a new design, which resembles a clump of bamboo with a windmill on top, making even more a link with the bamboo plant.

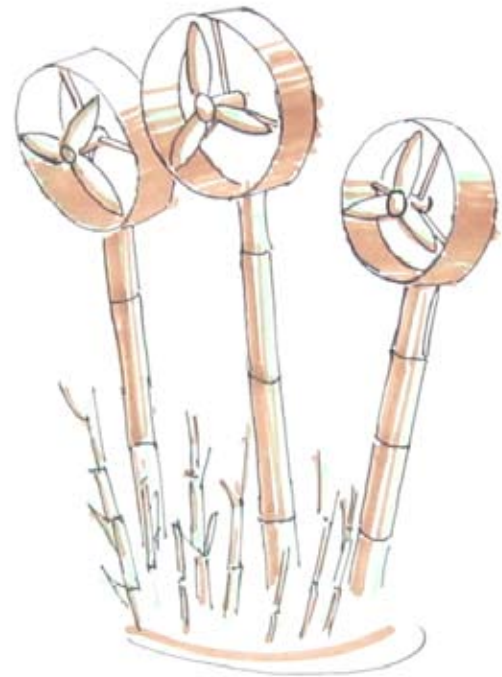

Figure 46

Impression of the design of a new bamboo windmill

10

| | |
|----------------------------|----|
| 10.1 Unique selling points | 75 |
| 10.2 Marketing campaigns | 76 |
| 10.3 Media coverage | 76 |

Marketing

This chapter gives inspiration for possible marketing campaigns for the product.

10.1 Unique selling points (USPs)

The marketing campaigns could communicate the USPs of the product in order to sell the product.

USPs

- The windmill generates renewable energy.
- The windmill communicates the environmental consciousness of the owner.
- The application of MBM in windmill wings is very innovative.
- The windmill is very durable and has a very simple design; low-tech and robust.
- The wing is made from local materials and is a new source of income for tribal craftsmen.

- The wing can be produced and used by the Kotwalia community (local for local).
- For the Kotwalia community using the windmill could be a leapfrog from no energy to renewable energy.
- The wings are cheaper than wings from steel.
- The windmill is truly sustainable: it combines renewable energy with a sustainable material and social entrepreneurship.

USPs that are found to be very attractive (during conversations and interviews):

- The product is sustainable in three ways (material, production, renewable energy).
- Which in turn communicates the sustainable consciousness of the owner.
- A high-tech and high quality application for a handmade product.

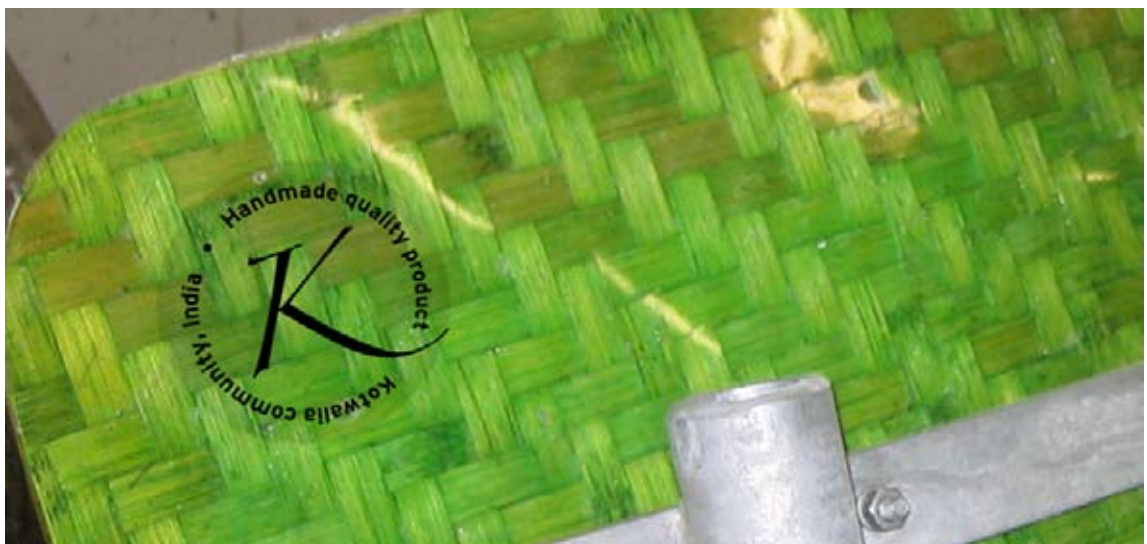

Figure 47
Craftmen's mark on the back of the wing

10.2 Marketing campaigns

A new product gets attention when a great story is surrounding it, in the case of bamboo wing, the story is already quite interesting because of the USPs, which could result in valuable free publicity.

To further create a story, three marketing campaigns could be used:

Crowdfunding

The facilities that are needed to start production of the wing by a tribal community could be funded through crowdfunding. Crowdfunding is a new way of raising capital. The concept is simple: a large number of people (the crowd) invest small amounts of money to accumulate into an investment large enough to finance a project. In return for an investment, the funders get something in return. For a very large investment, they get their own windmill. A crowdfunding campaign tests the potential of the product and creates a first group of interested customers.

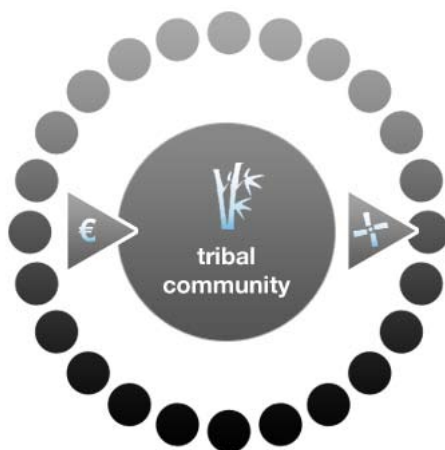

Buy 1, give 1

For every product you buy, you finance one product for a customer in India. The Indian customer receives your financial support as a microfinance loan and pays back the loan plus interest within 2 years. The loan agreement is facilitated by a local partner of an existing microfinance institution.



Map where the wind is being utilized

The locations of all windmills are indicated on a worldmap. Information about the owners is presented in a location based way. It is for instance possible to show how much energy your windmill generated over time. This campaign can be used in addition to one of the two other campaigns.



10.3 Media coverage

The bamboo wings have already generated quite some media attention and are covered on radio (amongst which NCRV radio), internet television, newspapers (amongst which AD) and numerous weblogs about sustainability, design and innovation (amongst which Treehugger, Inhabitat, Idealize and Materialicious).

Replacing Steel with Bamboo, Dutch Designer Gives the Windmill a Makeover

by Alex Davies, St. Paul, Minnesota on 06.22.10
SCIENCE & TECHNOLOGY

[Digg](#)
[reddit](#)
[share](#)
[StumbleUpon](#)
[Buzz up!](#)



All images Courtesy of Gijbert Koren

We've seen people do a lot with windmills - from making them at home to wearing them. Now Dutch designer Gijbert Koren has taken a step to make this age-old green technology even greener: replacing the windmill's steel wings with ones made of bamboo.

Koren believes the lower weight of the bamboo, woven in India, will make the windmill more efficient, and adds that aesthetically, they just look greener. The wings are still in testing, but Koren hopes to bring them to market soon.

Nederlander bezorgt bamboebugers booming business

24-09-2010



[Leren](#)
[Red to my](#)
[ThinkTyle](#)
[Print](#)

[1422](#)

BAMBOE, DUURZAAM, GUSBERT KOREN, INNOVATIE, WINDMOLEN

Ondernemer Gijbert Koren bedacht voor zijn afstudeerproject een windmolen met wieken van bamboe. Dat het duurzamer en goedkoper is, is wel duidelijk. Toch was het niet het doel van zijn creatie.

Tijdens een reis naar India voor zijn afstudeerproject aan de TU Delft viel Koren oog op de vele ambachtslieden die mandjes maakten van bamboe. Het viel hem op hoe arbeidsintensief dat was, terwijl ze er weinig geld mee verdienden. Koren bedacht hoe de inspanningen van de Indiase mannen beloond konden worden. "Ik dacht meteen: "Kan het niet interessanter?"

"Mijn doel was toen een geschikte toepassing te zoeken voor de bamboe," vertelt Koren. Hierbij ging hij op zoek naar iets wat paste bij de kwaliteit van het materiaal, en kwam zo bij windmolens uit. De wieken van Koren's afstudeerproject, afkomstig uit India en gemaakt door de ambachtslieden, zijn inmiddels geplaatst. "De ambachtslieden waren mijn inspiratie."

Bamboewieken op Bosmanmolentje

ambacht - Wie het Bosmanmolentje bij de Rijkswaard aan de Rijn in Heerlen wil zien, moet eerst even langs de Rijkswaard. De wieken zijn niet langer van metaal, maar van hout, van bamboe en geweven in India.

Het is een algeraad van de stroom. Gijbert Koren (1981) de Bosmanmolentje maakt de bosmanmolentjes die worden gebruikt voor de Rijkswaard in Heerlen. De wieken zijn niet langer van metaal, maar van hout, van bamboe en geweven in India.

De wieken worden gemaakt door ambachtslieden in India. Koren was op zoek naar een duurzame oplossing voor de wieken van de bosmanmolentjes. Hij ontdekte dat bamboe een goede keuze was. Bamboe is een duurzaam materiaal dat snel groeit en gemakkelijk te bewerken is. Koren heeft samen met ambachtslieden in India de wieken gemaakt. De wieken zijn nu klaar voor gebruik.



Gijbert Koren bij de molen. De moler wordt gebruikt om elektriciteit op te genereren. [www.rijksdienst.nl](#)

De wieken worden gemaakt door ambachtslieden in India. Koren was op zoek naar een duurzame oplossing voor de wieken van de bosmanmolentjes. Hij ontdekte dat bamboe een goede keuze was. Bamboe is een duurzaam materiaal dat snel groeit en gemakkelijk te bewerken is. Koren heeft samen met ambachtslieden in India de wieken gemaakt. De wieken zijn nu klaar voor gebruik.

Windmill wings from bamboo

Making windmills even more sustainable? Dutch designer Gijbert Koren has made bamboo wings for a classic windmill. The wings are made from two layers of handwoven bamboo mats and are protected and kept in shape by resin. The mats are handwoven by tribal craftsmen from India, giving them a new source of income. The windmill is suitable for the Western market, but also for rural markets in India, where less than half of the households have access to electricity.

[Share This](#) | [Visit Site](#)

ENERGY

Dutch Designer Gives His Country's Windmills Bamboo Wings

by Gijbert Koren, 06/23/10 [Read under: Renewable Energy, Sustainable Materials, Wind Power](#)

Dutch designer Gijbert Koren has given his country's famed windmills an even more sustainable edge by outfitting them with these fab new bamboo blades. Each blade has been constructed from two layers of handwoven bamboo mats that are reinforced with an eco-friendly resin. Koren's mats are handwoven by tribal craftsmen in India — this choice of materials helps sustain the crafts trade in these Indian tribes by offering them another source of income.

[READ MORE >](#)

[Vind ik leuk](#)
[Vind dit interessant](#)

[30](#)
[Digg](#)
[facebook](#)
[email](#)

Figure 48
Media coverage

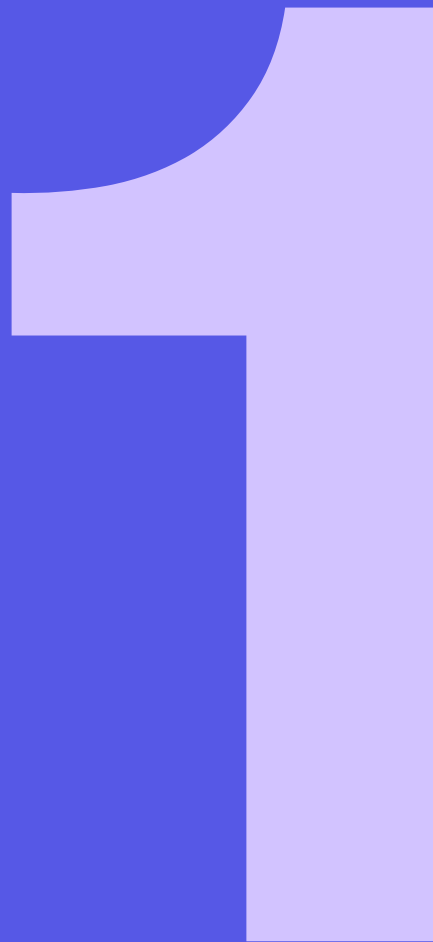
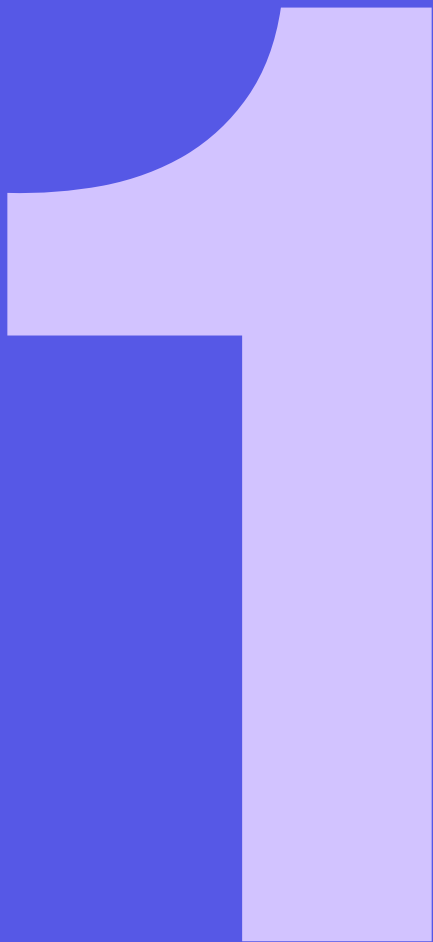

| | |
|-------------------|----|
| 11.1 Organisation | 79 |
| 11.2 Production | 80 |
| 11.3 Crowdfunding | 80 |

Business planning

This chapter briefly explains how to make a business out of the bamboo wing.

11.1 Organisation and strategy

An experienced and skilled social entrepreneur should be at the core of the organisation and make sure the Kotwalia community gets access to bamboo for production, education, tools and preservation methods.

Production of the wing is of course taken care of by the community of tribal craftsmen. The social entrepreneur is responsible for sales and export to importers in different countries. In the case of the wing for the Bosman windmill, the social entrepreneur could also be the importer himself, with Bosman Watermanagement being the only client.

After testing the first prototype, Bosman Watermanagement and two of its clients (Rabobank Hoeksche Waard and a local government) have already shown interest in this product. Rabobank's interest is based on the ability to communicate its environmental and social awareness. For the local government the bamboo wings are aesthetically pleasing because of their colour, when placed in a park.

To be able to run a sustainable business, more products should be developed, like wings for other windmill. Next to this, a special bamboo windmill should be developed, as proposed in chapter 9.



Figure 49
New value chain

11.2 Production

The production process for production by tribal craftsmen will be slightly different from the production of the prototype, due to limited access to capital and the difficulty of maintenance of complex tools in tribal areas.

As resin, the craftsmen can switch to the less toxic epoxy which is used for the prototype. The price of epoxy is comparable to the price of phenolic resins, which is currently being used by the Kotwalia community.

A low-tech production technique is hand lay-up moulding of several layers of mats on a flat mould. The plates will stay flexible for a few days and can be fixed on a rod from bamboo, which should get a preservative treatment.

The costs per wing is currently €80,-. The bamboo wing will cost approximately €20,-.

11.3 Crowdfunding

Although the costs involved are relatively low for Western standards, the production of the wing will require an initial capital investment to kickstart the project.

This first investment could be harvested from first customers by pre-selling the product through crowdfunding, as proposed in chapter 10.



1

2

| | |
|------------------------|----|
| 12.1 System conditions | 83 |
| 12.2 Cradle to Cradle | 83 |
| 12.3 LCA | 84 |

Sustainability analysis

This chapter is an analysis of the sustainability of the product. The starting points for sustainability that have been stated in chapter 3 are used to evaluate the product.

12.1 System conditions for sustainable development

One of the starting points is defined by The Natural Step as the system conditions for sustainable development. The bamboo wings are evaluated on the incorporation with the system conditions:

No increasing concentrations of substances extracted from the Earth's crust

By replacing metal with bamboo, less material is extracted from the Earth's crust.

No increasing concentrations of substances produced by society

As soon as a bio resin is available on the market, the substances produced and used during the production will not be harmful.

The transport of the wings will remain a challenge and can be solved once renewable energy will be available for over-seas freight transport.

No over-harvesting or other forms of ecosystem manipulation

Over-harvesting is not a problem in the area where the Kotwalia community lives; the forests are large enough to supply them with bamboo.

Resources are used fairly and efficiently in order to meet basic human needs worldwide

The profit generated with the product is fairly distributed amongst the social entrepreneur and the craftsmen, to give them the ability to meet their basic human needs.

The scoring on the system conditions is not bad. Replacement of epoxy with a bio resin and sustainable transport from India will remain points of attention.

12.2 Cradle to Cradle

Another starting point is the Cradle to Cradle sustainable design tool.

Waste = food

Bamboo combined with a resin creates a composite material, which can not be upcycled for use in another high quality application. Until there is a bio resin available, this means that at the end of their lifecycle the wings are waste in the technosphere.

Use current solar income

The production process uses a minimum of energy, while transport has quite a large impact as mentioned before.

Celebrate diversity

Development by tribal craftsmen in India stimulates diversity in production processes and could inspire others to do the same.

The product is not designed for disassembly, since it is made from a composite material, which also reduces the recyclability. Also because of the use of epoxy resin and transporting the product from India to the Netherlands, the product doesn't fit too well with the starting points of the Cradle to Cradle tool.

12.3 LCA

The Eco-costs / Value Ratio (EVR) (Vogtländer et al. 2002) is another tool, which is used to assess the lifecycle impact of the bamboo wing and to compare it to the impact of the original wing. The source of all eco-costs is Ecocost 2007 LCA Database, unless mentioned otherwise. The weight is shown in kg, the eco-costs are shown in euro's.

The eco-costs of the bamboo wing, excluding rod:

| Material | Weight | Eco-costs/kg | Eco-costs |
|--------------|--------|--------------|--------------|
| Bamboo | 0.6 | 0.842 | 0.505 |
| Epoxy | 1.5 | 0.995 | 1.493 |
| Total | | | 1.998 |

(For bamboo, the eco-costs of bamboo stems from China, including transport to the Netherlands has been used (Van der Lugt et al. 2009). The real eco-costs will be slightly lower, because mats have a lower volume than stems.)

The eco-costs of the original aluminum wing, excluding rod:

| Material | Weight | Eco-costs/kg | Eco-costs |
|--------------|--------|--------------|--------------|
| Alu | 1.3 | 2.875 | 3.738 |
| Total | | | 3.738 |

The eco-costs of the bamboo wing, including bamboo rod:

| Material | Weight | Eco-costs/kg | Eco-costs |
|--------------|--------|--------------|--------------|
| Bamboo | 1.4 | 0.842 | 1.154 |
| Epoxy | 1.5 | 0.995 | 1.493 |
| Total | | | 2.647 |

The eco-costs of the bamboo wing, including original steel rod:

| Material | Weight | Eco-costs/kg | Eco-costs |
|--------------|--------|--------------|--------------|
| Steel | 8 | 0.660 | 5.280 |
| Bamboo | 0.6 | 0.842 | 0.505 |
| Epoxy | 1.5 | 0.995 | 1.493 |
| Total | | | 7.278 |

The eco-costs of the original aluminum wing, including original steel rod:

| Material | Weight | Eco-costs/kg | Eco-costs |
|--------------|--------|--------------|--------------|
| Steel | 8 | 0.660 | 5.280 |
| Alu | 1.3 | 2.875 | 3.738 |
| Total | | | 9.018 |

The bamboo wing has lower eco-costs than the original wing. Using a bamboo rod, further decreases the eco-costs.

The figure on the next page, graphically shows the total eco-costs of the above calculated cases.

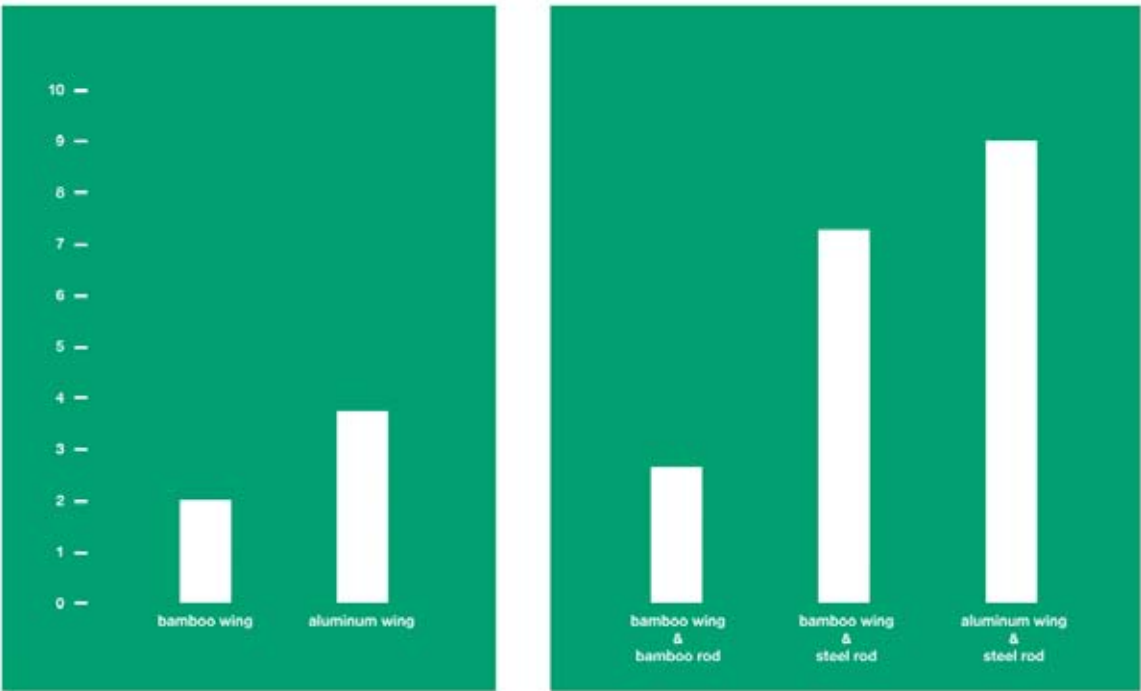

Figure 50
Eco-costs

13

| | |
|--------------------------|----|
| 13.1 Global urban market | 88 |
| 13.2 New bamboo material | 89 |
| 13.3 Kotwalia community | 89 |
| 13.4 Social entrepreneur | 89 |

Conclusions

After analyzing the sustainability of the product, there are four starting points left, which are stated in the first chapter of this report and elaborated throughout the report.

The starting points for which the product is still to be evaluated:

- Designed for the global urban market.
- New bamboo material: A bamboo material that is currently not available on the Western market will be used for the product.
- Income generation for tribal craftsmen: The target producers for the product are tribal craftsmen from India.
- Me: I will always keep in mind the potential for starting a company to produce and sell the product.



Figure 51
Starting points

13.1 Global urban market

The criterium for making the product fit the global urban market, can be split into more specific criteria. Not all these criteria have to be met. For all three main criteria, at least one subcriterium should be met. The subcriteria were intended to serve as inspiration.

Fit the global urban consumer

Status

Authenticity

The product appeals to a feeling of authenticity, while on the other hand it gives the owner status in a very special way - some kind of authenticity status.



Fit current consumer trends

Buying the experience

Econciierge & ecoeasy

e Conversations

Innovation Boom

Happy ending

Design-centric

Global citizens

Mapmania

The product mainly fits with the trend of Global Citizenship and social entrepreneurship, supporting local and decentralized production of the product.

When the product is in use, it supports decentralized production of energy.



A second trend with which the product fits, is Innovation Boom, which is about smart and price competitive innovations. The bamboo wing is such an unexpected innovation that greatly reduces the price of the original wings.



When the marketing campaigns would be further elaborated, the other trends could also be used as inspiration to make the product fit the user more.

Fit urban sustainability challenges

Waste and pollution

Water and energy supply shortages

Traffic congestions

Health problems

Limited green spaces

Poverty and malnutrition

Social security and public safety problems

Clearly, the windmill wing fits with the challenge to provide energy to counter-

balance energy supply shortages.



13.2 New bamboo material

A bamboo material that is not yet used on the global market has been used for the product. A name for the material has been suggested: Molded Bamboo Mats (MBM).

The product that is made from the new material had to adhere to the criterium of remarkability, being a potential enabler application for further commercialisation of the new material.

| Remarkability |
|------------------------------------------------|
| Remarkable |
| Simple value chain |
| High fault tolerance |
| Small market |
| High visibility |
| Low material-cost sensitivity |
| Provides the material with credibility |
| Demonstrates the unique values of the material |

The product has been featured in the media, which could be used as argument for being remarkable.

Since the product is quite simple, the value chain is also quite simple and the manufacturability is very good. The fault tolerance is moderate. The market is quite small and the product has a high visibility. The surprised reactions on the bamboo wings

indicate that it demonstrates the qualities of bamboo and provides the material with credibility. To conclude, the product scores excellent on remarkability and being a potential enabler application.

13.3 Kotwalia community

The product should also fit the tribal producers; they should be able to produce it and earn a fair wage from production.

Value of the product for the craftsmen

Profit generated with the product

Relative profit for the craftsmen

Competing with the original windmill wing which costs €80,-, the bamboo wing will cost approximately €20,-, which leaves ample opportunity for profits (if the value chain doesn't become too complex).

Technology level needed for production

Level of standardisation and quality

Complexity of the product and production

During prototyping, a very simple production method of hand lay-up moulding on a flat mould was discovered for this product, which is very well possible

Feedback from Indian experts also show the same conclusions (source: personal communication with experts in the field of bamboo crafts).

13.4 The social entrepreneur

All in all, the product turns out to be an entrepreneurial opportunity, with customers of Bosman Watermanagement already being interested in the bamboo wings. This can only mean one thing: a very interesting opportunity for a social entrepreneur and other stakeholders to continue with this product.

14

| | |
|---------------------|----|
| 14.1 Target market | 91 |
| 14.2 Bamboo | 91 |
| 14.3 Sustainability | 91 |
| 14.4 India | 93 |

Discussion

This report does not conclude with a conclusion, but with a discussion, being a more personal way to reflect and evaluate on aspects of this project.

14.1 Target market

During this project, I have kind of switched the focus of the target market from the Western market to the global urban market. In the end, the final product is also very well suitable for the rural Indian market, maybe even more suitable than for urban markets (due to its constructional design). The reason for this switch is my experiences in India with the Kotwalia community; it seemed much more interesting to make a product that is also useful to them, a product that they can relate to, because they also use it for themselves. It might seem a bit strange, but to me this switch has been very natural.

14.2 Bamboo

Is bamboo the sustainable material of the future? The first sentence of my graduation assignment suggests it could be. *“Bamboo is a material with a high - but latent - potential for application in a plethora of products.”* Proponents are saying this for years now. But why isn't there more bamboo around us? Or, in other words, considering the potential of bamboo, why are there so few bamboo products on the market? (Dufrénot 2009) I wonder whether bamboo is really that interesting as a material; there are enough

alternatives available on the market, from wood to metal and from fiber reinforced plastics to jute.

But still, I find bamboo a very interesting material with which you can just choose to work with.

14.3 Sustainability

Bamboo is regarded as a sustainable material, but when it's transported from Asia to the West, the environmental burden of the transport makes the material a whole lot less sustainable. This has been one of the main conclusions of the PhD research of Pablo van der Lugt and is of course very well researched.

After visiting India, I have developed my own vision on Pablo's conclusion: high quality products are in India also known as 'export quality products'. The producers are very proud of such a status and earn very well by exporting their products to the rich West. Selling products to the West is for many producers and service providers the ultimate goal. Isn't this great? And aren't we the champions of this free market thinking? Aren't we the ones who are getting most of our products made in Asia? Then, who are we to look down at producers of bamboo products when they want to export their products to the West?!



14.4 India

Some people from India, whom I have met outside and inside India, were surprised that I went to a developing country to do my graduation project, while a rich country like the Netherlands offers many opportunities to do a great project. Opposite to this, there were people who saw my project as some kind of voluntary aid work to help poor people in India.

The truth is that I went to India to see and learn. And this is what I did. I saw the unbelievable quality of very skilled craftsmen, I got to know very interesting people, saw parts of this very beautiful country, made lots of mistakes and also learned a lot. I hope that I will visit India again in the future and see and learn more and more...

References

- Anderson, J.D. jr. 1999. A History of Aerodynamics. Cambridge University Press, Cambridge, UK.
- Brundtland et al. 1987. World Commission on Environment and Development, Our Common Future. Oxford University Press, Oxford, UK.
- Burt, R.S. 2005. Brokerage and Closure: An Introduction to Social Capital. Oxford University Press, Oxford, UK.
- Crul, M.R.M. et al. 2009. Design for Sustainability, a Step-by-Step Approach. United Nations Environment Programme, Paris, France.
- Dieu, T.V. et al. 2004. Study on Fabrication of BMC Laminates Based on Unsaturated Polyester Resin Reinforced by Hybrid Bamboo/Glass Fibers, JSME International Journal.
- Dufrénot, X. 2009. Bamboo Housing : on the Dream-World of Bamboo and “Crusoism”. Bamboo-plantations, Yahoo Groups.
- Godin, S. 2003. Purple Cow: Transform your Business by Being Remarkable.
- Graham, L.D. 2008. Biological adhesives from nature. In: Encyclopedia of Biomaterials and Biomedical Engineering, 2nd ed., Informa Healthcare, New York & London, vol. 1, pages 236-253.
- GWEC. 2008. Global Wind Report 2008. Global Wind Energy Council, Belgium.
- Hollingshead, A.B. 1975. Four Factor Index of Social Status. Yale University, New Haven, USA.
- Holmberg J. and Robèrt K-H. 2000. Backcasting from non-overlapping sustainability principles - a framework for strategic planning. International Journal of Sustainable Development and World Ecology, vol. 7, pages 291-308.
- INBAR. 2000. Acceptance Criteria for Structural Bamboo. INBAR, Beijing, China.
- INBAR & IPIRTI, Transfer of Technology Model: Bamboo Mat Board. INBAR, Beijing, China.
- Inglehart, R. 1971. The Silent Revolution in Europe: Intergenerational Change in Post-Industrial Societies, American Political Science Review, vol. 65, pages 991-1017.
- Insight Instore 2009. Design Trends, Global & Indian Trends and their Implications on key sectors. Insight Instore, Bangalore, India.
- Jadranka, C. and Ter Horst, E. 2007. Urban wind turbines. Rencom, the Netherlands.
- Jain, S. et al. 1992. Mechanical behaviour of bamboo and bamboo composite. Journal of Materials Science, vol. 27, pages 4598-4604.
- Janssen, J.J.A. 2000. Designing and Building with Bamboo. INBAR Technical Report 20. INBAR, Beijing, China.

-
- Koren, G.W. et al. 2008. Haaglanden 2060: The road towards a sustainable transport system. TU Delft, Delft, the Netherlands.
- Kraas, F. et al. 2005. Megacities - our global urban future. Earth Sciences for Society Foundation, Leiden, The Netherlands.
- Laemlaksakul, V. 2008. Innovative Design of Laminated Bamboo Furniture Using Finite Element Method. International Journal of Mathematics and Computers in Simulation, vol. 2, pages 274-284.
- Larasati, D. 1999. Uncovering the green gold of Indonesia. INBAR Working Paper 31. INBAR, Beijing, China.
- McDonough W. and Braungart. M. 2002. Cradle to Cradle: Remaking the way we make things.
- Mehta, S. 2009. Base Line Survey of Kotwalia Community in Tapi District. Eklavya Foundation and Social Team of Kotwalia Youth Volunteers Tapi District, India.
- Modi, V. 2005. Improving Electricity Services in Rural India. CGSD Working Paper No. 30. The Earth Institute at Columbia University, New York, USA.
- Moore, M. et al. 2003. Global urbanization and impact on health. International Journal of Hygiene and Environmental Health, vol. 206, pages 269-278.
- Motivaction 1996-2009. Mentality™: waarden en leefstijl onderzoek. Motivaction, Amsterdam, the Netherlands.
- Musso, C.S. 2005. Beating the System: Accelerating Commercialization of New Materials. Massachusetts Institute of Technology, Cambridge, USA.
- Netravali, A.N. and Chabba S. 2003. Composites get greener. Materials Today.
- Okubo, K. et al. 2004. Development of bamboo-based polymer composites and their mechanical properties, Doshisha University, Kyoto, Japan.
- Papanek, V. 1985. Design for the Real World.
- Pine, J. and Gilmore, J. 1999. The Experience Economy.
- Platts, M.J. 2006. Wind energy turns to bamboo. Energy Materials, vol. 1, pages 84-87.
- Qisheng, Zhang and Jiang Shenxue and Tang Yongyu 2003. Industrial Utilization on Bamboo. INBAR Technical Report 26. INBAR, Beijing, China.
- Reubens, R. 2010. Diagnostic Study Report for Development of Bamboo Craft Cluster, National Bank for Agriculture and Rural Development, India.
- Robert I et al. 2003. The implications of current and future urbanization for global protected areas and biodiversity conservation. Biological Conservation Vol. 141, pages 1695-1703.
- Robèrt K-H. et al. 2001. Strategic sustainable development – selection, design and synergies of applied tools. Journal of Cleaner Production, vol. 10, pages 197-214.
- Rogers, E.M. 1995. Diffusion of innovations.
- Thwe, M.M. and Liao, K. 2003. Durability of bamboo-glass fiber reinforced polymer matrix hybrid composites. Composites Science and Technology, vol. 63, pages 375-387.
- Trendwatching.com 2008. Half a dozen consumer trends for 2009. Trendwatching, Amsterdam, the Netherlands.
- Trendwatching.com 2009. 10 crucial consumer trends for 2010. Trendwatching, Amsterdam, the Netherlands.



-
- Tribal Development Department. Note on Bamboo Based Livelihood. Development and Research Institute of Gujarat. Tribal Development Department, Ahmedabad, India.
- UN (United Nations) 2002. World Urbanization Prospects. The 2001 Revision. United Nations, New York, USA.
- Van der Lugt, P. 2007. Dutch Design meets Bamboo.
- Van der Lugt, P. 2008. Design Interventions for Stimulating Bamboo Commercialization - Dutch Design meets Bamboo as a Replicable Model. Delft University of Technology, Delft, the Netherlands.
- Van der Lugt, P. and Lobovikov, M. 2008. Markets for bamboo products in the West. Bois et forets des Tropiques, vol. 295, pages 81-90.
- Van der Lugt, P. et al. 2009. Bamboo, a Sustainable Solution for Western Europe Design Cases, LCAs and Land-use. INBAR Technical Report No. 30. INBAR, Beijing, China.
- Van Kesteren, I.E.H. and Kandachar, P.V. 2004. Commercialization of new materials in consumer goods. Proceedings of the international conference of the Design Research Society, Futureground, Melbourne, Australia.
- Vásquez, I. 2001. Ending Mass Poverty.
- Vogtländer, J.G. et al. 2002. Communicating the eco-efficiency of products and services by means of the eco-costs/value model. Journal of Cleaner Production, vol. 10, pages 57-67.
- WHO. 2009. The World Health Report 2009. World Health Organisation, New York, USA.
- WHO. 2009. 10 facts about water scarcity. World Health Organisation, New York, USA.
- Williams, J.C. 2004. High Performance Materials Development in the 21st Century: Trends and Directions. Materials Science Forum.
- WWEA. 2010. World Wind Energy Report 2009. World Wind Energy Association, Germany.

Appendices

| | | |
|-----------|--------------------------------------------------------|------------|
| 1 | Overview of bamboo materials | 100 |
| 2 | Remarkable bamboo products | 102 |
| 3 | Semi-industrial production of MBM products | 106 |
| 4 | Creative session 1, TU Delft, NL | 108 |
| 5 | Creative session 2, TU Delft, NL | 110 |
| 6 | Workshop Kotwalia community, India | 112 |
| 7 | The culture of the Kotwalia community | 116 |
| 8 | Field visit CIBART production unit, Ukai, India | 118 |
| 9 | Outline workshop, Ukai, India | 120 |
| 10 | Scoring of product ideas | 122 |
| 11 | iPhone cases | 124 |
| 12 | Urban windmills | 126 |
| 13 | Wind energy in India | 128 |
| 14 | Technical drawings Bosman windmill | 130 |
| 15 | Working Stress Design | 132 |
| 16 | Tensile strength tests | 134 |
| 17 | Prototyping | 136 |
| 18 | Various material samples | 138 |

Appendix 1 - Overview of bamboo materials

An overview of bamboo materials that are currently available on the market.

| | Material | Production | Properties | Applications |
|-------------------------------------------------------------------------------------|---------------------------------|-------------------------------------------------------------------------------------------------------------------------------------|-------------------------------------------------------------------------------------------------------------------------------------|-----------------------------------------------------------------------------------------------|
|  | Bamboo stem | Lightweight, circular | | Colonial furniture, architecture, scaffolding |
|  | Bamboo strips | Stems are cut or sawn into strips | Lightweight, products are foldable (like Luxaflex) | Low quality interior applications, like baskets and curtains |
|  | Plybamboo | Strips are sawn into straight beams, bleached or carbonized, dried, glued together and pressed together, sawn into beams and sanded | When strips are placed cross-wise the board is very stiff and can take pressure in different directions, available in lots of sizes | Mainly floors, but also other high quality interior applications, like kitchens and furniture |
|  | Plybamboo Veneer | Plybamboo cut into thin veneer boards | See through, breaks easily | Mainly used for decoration purposes |
|  | Strand Woven Bamboo | Strips are sawn and split, carbonized, dried, crushed, glued and pressed together, heated to activate the glue and sawn into beams | High hardness and density | Outdoor: architecture, public furniture and in gardens |
|  | Bamboo Mats (or woven products) | Thin bamboo slivers are hand-woven into mats | Lightweight, flexible | Mainly baskets |
|  | Bamboo Mat Boards | Bamboo mats glued together | Lightweight, flexible, high impact resistance | Temporary housing |



Appendix 2 - Remarkable bamboo products



ASUS bamboo series

The bamboo series laptop is a green icon for ASUS. The laptop is finished with a layer of bamboo veneer.

Indigo Bamboo Snoboard

The core of this snowboard is made from carbon fiber and the surface from bamboo veneer to give this board its natural looks.



Terminal T4 Barajas Airport

The roof of terminal T4 at Barajas Airport is covered with 200,000 square meters of bamboo veneer. The veneer is built up of 5 layers of 1 mm thick.

Artek sustainable Bambu furniture

This chair by Henrik Tjaerby for Artek is made from plywood and has a bamboo veneer finish. The elegant curves show the flexibility of the material.



Dell bamboo packaging

Dell announced that it will ship its Inspiron mini laptop in packaging made from bamboo (as alternative to paper pulp, foam and corrugate board).



Bamboo Soil Clock

This bamboo clock by Marieke Staps works with copper and zinc electrodes that plug straight into soil. The soil functions as a conductive medium through which an electrical charge can flow – providing a natural energy source.



BamGoo

This 60 kg electric vehicle is made by Kyoto University. The body is made from bamboo sticks with a high hardness.

Renovo Pandurban Commuter

The frame of this bike is made from plybamboo, which gives the bike a unique natural look.





Bamboo Bike Studio

At Bamboo Bike Studio, customers can build their own bamboo bike during a weekend workshop.

Mitsubishi car doors

Mitsubishi is developing bamboo fiber fortified car doors.

Prins Clausprijs for Simon Velez

Columbian architect Simon Velez received the Prins Clausprijs for his bamboo buildings.

Fashion4Home bamboo furniture line

Fashion4Home lets its consumers vote which designs to get manufactured by voting.



Appendix 3 - Semi-industrial production of MBM products

1



Cross cutting culms

The first step in processing bamboo for any application is cross-cutting the culm into sections of predefined length. Depending on the final application, culms can be either fresh or dry prior to cross-cutting. Sliver making is easier when the culms have a high moisture content and thus when they are fresh. The age and species of the bamboo culm also determine the suitability for a certain application. Culms with an age of 5 to 8 years, have higher and more stable mechanical properties and are therefore better fit for applications that require heavy use: bamboo mat boards for instance. Culms with an age of 3 to 4 years, are usually used for products with a more decorative purpose, such as fine mats and baskets.

2



Splitting

Bamboo culms can either be split manually with a splitting tool, or mechanically by means of a splitting machine.

3



Rough planing

The strips obtained after splitting the culm can of course be used in their raw form for a number of low-end applications, but for further processing it is necessary to remove the green epidermal layer and yellow inner layer, together with the inner and outer joints. Removing the inner and outer wall makes the surface and preservative treatments such as bleaching and carbonising, but also eventual adhesive bonds, between splits more effective. This operation is traditionally carried out by hand, but for larger quantities it is performed on a rough planing machine.

4



Preserving

There are a number of different preservative treatments to protect bamboo from the attack of insects and fungus. The most prevailing one for slivers is boiling - bleaching. The treatment eliminates any soluble organic substances susceptible to attract pests, as well as staining the fibres in a more or less uniform colouration.

During the boiling - bleaching operation the strips are submerged in a bath of: water, hydrogen peroxide, insecticide and preservatives and are boiled for 6 to 8 hours. The resulting bamboo has a natural blond colouration.

5

Drying

The water content of bamboo after boiling - bleaching and carbonising is approximately 35 to 50%. For further processing the moisture content needs to be reduced to 10% in order to obtain a material that is dimensionally stable.

Besides to avoid crack formation and deformation under the influence of varying air humidity in a later stage, it is important that any bamboo material is dried under the right conditions for a considerable period of time.

Slivers are either air-dried or kiln dried depending on the facilities. When available, kiln driers are heated by burning the waste of the production process (saw-dust, shavings, cut-offs) and generally produce better results regarding moisture content.

6



Slivering

Slivers of bamboo are generally between 5 and 15 mm wide and 0.6 to 2.5 mm thick. The thinner the slivers, the more flexible the mat. Strips on the other hand are usually 15 to 20 mm wide and have a thickness approximately equal to that of the culm wall. Hence in order to obtain slivers from strips, the strips have to go through a number of splitting operations until the desired dimensions are reached. Splitting of bamboo strips into slivers can either occur in a radial or tangential direction. This operation is traditionally carried out using a machete knife, but for industrial processing special slivering machines perform the task more efficiently.

7



Weaving

Weaving is perhaps the most traditional but also one of the most effective methods to join bamboo slivers and threads. At the crossing points of the slivers and threads, the stress in the material produces a frictional resistance which preserves the shape of the structure even under high loading.

There are hundreds of different techniques available to weave both 3 dimensional (basketry) and 2 dimensional objects (mats). These techniques can basically be divided into 5 categories: square, hexagonal, orthogonal, bottom and border weaving. A great variety of patterns and motifs can be accomplished in each category, and especially with the use of slivers dyed in different colours.

8

Storing

Woven mats can be air-dried further and stored without any treatment for 3-4 weeks. Prophylactic treatments must be applied if they are likely to be stored for a longer period. The simplest and most effective treatment for mats, if they are not likely to be exposed to water, is to spray them with a 1% solution of a mixture of boric acid and borax in a 1:1 ratio.

Treated mats are dried either in the air or in a drier, and stored under cover. Treated mats should not come into contact with the ground and can be stored for 3 to 4 months without deterioration. They must be stored in well-ventilated locations with low relative humidity and negligible changes in humidity. The chances of fungal or insect attack are increased if the relative humidity is very high. Mats should be resprayed once every three months and should be checked regularly (at least once per fortnight) for any signs of fungal growth, mould and/or borer attack.

9a



Lay-up moulding/contact moulding

Mats woven out of fine slivers are very pliable and therefore very much suited for lay-up methods. One can either lay the mats in a mould, or wrap them around a core made of a different material, and then impregnate them with a resin. Air-inclusions are subsequently removed by means of a roller or a brush. Finally setting of the material can occur at atmospheric pressure and room temperature, but in order to improve the quality of the final product, high pressure and high temperatures, by means of pressure or vacuum bagging are recommended. Lay-up methods are typical for products with a large surface to wall-thickness ratio and shapes with a single or double curvature.

9b

Adhesive coating

Mats intended for lamination are made of slivers with a thickness in the range of 0.6 to 1.0 mm and a width in the range of 5 to 15 mm.

After the mats have been dried to 6 to 12% moisture content, they are dipped into a resin (for instance phenol formaldehyde) for about 5 minutes and subsequently suspended in an inclined position for about 30 minutes. In order to let the resin permeate the surface of the slivers and the gaps located at the intersections, the mats are again left to dry in a kiln for 2 hours at 80 °C.

10b

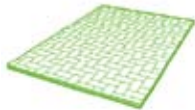

Assembling

Bamboo mats can either be laminated on each other, or on other materials. Because bamboo mats are woven, their mechanical properties are more or less isotropic and therefore they can be assembled both in odd and even numbers.

11b



Hot pressing

The actual process of hot pressing takes about 4 to 15 minutes depending on the number of layers and the type of adhesive applied. Also the temperature for hot pressing is directly related to the type of adhesive used. Phenol formaldehyde for instance cures at a temperature between 140 and 150 °C, while urea formaldehyde cures at a temperature between 110 and 120 °C. To effectively bond the mats together, a pressure of 2.5 to 4 MPa is needed.

To prevent deformation of the final products they are either cooled under the load of the press, or stacked on top of each other.

Resin: Phenol formaldehyde (PF)

Ingredients:

- Phenol: Pure phenol is a white crystalline solid with a melting point of 43 °C.
- Formaldehyde: Formaldehyde is a gas usually available as formalin which is a solution of 37% concentration (by weight) in water with methyl alcohol as a stabilizer.
- Sodium hydroxide: Sodium hydroxide is available in pellets as well as in flake form. It is white in colour, hygroscopic and highly soluble in water.

The process of resin manufacturing:

The resin is prepared in a resin kettle or batch resin reactor made of either mild steel or stainless steel. One hundred parts by weight of phenol is charged into a resin kettle followed by 150 to 200 parts

by weight of 37% formalin and stirring is commenced. Between five and fifteen parts by weight of sodium hydroxide dissolved in double the quantity of water is then added. Stirring is continued. The chemical reaction starts after the three components have been mixed and takes about 90 minutes to complete. The temperature of the reaction mixture is maintained between 82 and 85 °C. During the course of the reaction, the flow time of the resin is checked periodically. The reaction is stopped when the flow time increases to around 15 seconds when the resin is hot. The resin is then cooled to room temperature by circulating cold water in the jacket of the kettle. The cooled resin is discharged from the kettle and stored in airtight containers.

Appendix 4 - Creative session 1, TU Delft, NL

To get out of the box and creative ideas for applications of MBM, a creative session with design students is organized. The participants are all master students at the faculty of Industrial Design Engineering at TU Delft. None of them have experience with bamboo.

Program

- Welcome
- Introduction of participants (icebreaker)
- Purge (shout first ideas and write on a post-it)
- Stepping stone (use a random picture from a collage to associate and generate ideas)
- Trends (choose one trend and generate ideas)
- Rank all ideas on potential to generate profit for craftsmen and the technology level needed for production.

Participants

Jaap Frolich
Louis Pierre Geerinckx
Bram Hendriks
Aditya Pawar

Results

An overview of all ideas generated during the creative session.

The best (viable to make and sell) ideas are chosen by the participants and highlighted in green.

Applications:

- sunglasses
- japanese shoes
- snowboard
- sandwich panels
- sanding paper
- queens chair
- mail and postage packaging
- plakkies (flip flops)
- clothes
- customer cuts product out of flat panel
- personalize your own space by adaptive bamboo
- art
- partitioning system for offices (cubicals)
- hammock
- pre compressed plate

- panels for buildings
- boat
- rice bowl
- fruit bowl
- sustainable packaging
- board game
- luggage
- sunblocker above window
- plates
- coffee cup holders
- ring
- lamp
- shoes
- beach mat
- movable screens (for privacy)
- cuttlery
- hat
- wall paper
- bank card
- aquarium

Stories:

- corporate vs domestic (create a corporate image around product, while it is in reality small scale)
- explain to your father; design for intergeneration
- give the product a soul with a character and life route
- add a bamboo plant for the garden to grow your own material
- handmade
- timeless

Additions:

- laser engraving or cutting
- smoke patterns
- burning
- weaver signs the product

Material possibilities:

- re-shaping at home by steaming
- melt your own design
- customization; invent own patterns
- barcode from slivers
- pixel art
- duo tone (2 sliver colours)
- colour patterns
- changes colour with humidity or temperature
- natural vs unnatural

-
- add electricity wire to weaving
 - add light to weaving
 - add other fibers to weaving
 - add transparent slivers to weaving
 - shine patterns (shadows)
 - shine with colour light on the bamboo
 - gradient
 - twist slivers to change colour
 - memory; develop over time
 - vary tension between slives to create a gradient
 - reflect light

Appendix 5 - Creative session 2, TU Delft, NL

To get inspiration and interaction with designers who are using bamboo as a material, a second creative session is organized. The designers who participated in Pablo van der Lugt's workshop Dutch Design Meets Bamboo (DDMB) were invited, of which five participated in this workshop, additionally four new participants were found for this workshop.

All participants were asked to bring samples and tell something about their experiences with MBM and bamboo in general.

| Program | |
|---------|---------------------------------------------------------------------------------------------------|
| 15:00 | Small exposition of materials, samples and products from bamboo and other woven natural materials |
| 15:10 | Welcome |
| 15:15 | Introduction all participants to each other |
| 15:25 | Presentation Gijsbert Koren about bamboo and MBM |
| 15:45 | Presentation Ronald Koster about using PLA as a resin |
| 15:55 | First reactions, ideas and own experiences |
| 16:10 | Negative aspects of MBM |
| 16:20 | Positive aspects of MBM |
| 16:30 | Why use MBM? |
| 16:40 | Ideas for applications |
| 16:55 | Hand out of a booklet about MBM and material for prototyping |

After the workshop, there will hopefully be interaction between the graduate student and the participants about MBM and possible applications. By means of a newsletter, the graduate student will keep the participants updated about his progression.

| Participants | |
|------------------|--------------------------------------------------|
| Licia Jasperse | Assistant during workshop |
| David Derksen | Graduated from Design Academy |
| Erik | Internship at Maarten Baptist (participant DDMB) |
| Marco Groenen | Participant DDMB |
| Rene Veenhuizen | Participant DDMB |
| Ad Kil | Participant DDMB |
| Ronald Koster | Participant DDMB |
| John Manschot | Designing bamboo furniture |
| Ed van Engelen | Participant DDMB |
| Thies Timmermans | Designing bamboo furniture |

Results

An overview of all ideas generated during the creative session.

Negative aspects of MBM:

- The fibers will crack when bent too much; bent plywood can be used as base material to assure good mechanical properties of the product
- Consumers seem to think that bamboo is sustainable, but the use of a toxic resin makes it unsustainable (the stems however, are a sustainable material)
- Bamboo grows in the developing countries, wood and jute grow in Western countries and are a better alternative from an ecological point of view
- No separation of material components possible; it should be safe to incinerate the product

Positive aspects of MBM:

- Fast growing (high yield)
- High strength
- Flexible
- Fibers in one direction
- Social equitability; the creation of labour
- Alternative for tropical hardwood

Why use MBM?

- Appealing material
- New
- Good plant for reforestation and groundwater preservation
- Sustainable image
- Social equitability
- Natural looks
- Possible to use as local material (in developing countries)

Ideas for applications:

- 3D weaving, to be able to make more extreme shapes
- Design a weaving pattern (and a 3D shape) especially for a certain product
- Replace polyester resin with PLA or PureBond
- Wooden shoes from mats
- Use a mechanical intervention to fix mats in a shape instead of resin
- Tubes
- Cars and dashboards
- Wings of airplanes
- Combine with coconut pulp (contains a natural resin)



Appendix 6 - Workshop Kotwalia community, India

To get insight into the products the Kotwalia community is currently producing and the techniques they are using, a 4-day workshop is organised. A group of 7 bamboo craftsmen were hired to produce one item of all products they produce. The craftsmen received Rs 100 and two meals per day for their participation and an additional Rs 100 would be rewarded to the craftsman who made the best product (high quality and value, chosen by the observers).

| Observers | |
|-------------------|---------------------------|
| Kaushik Chaudhary | Regional coordinator TBDC |
| Sonal Mehta | Director TBDC |
| Rebecca Reubens | Director TBDC |
| Gijsbert Koren | Graduate student |
| Licia Jasperse | Research associate INBAR |
| Anuj Sharma | Graduate student |

On the next two pages an overview of produced products and their selling price can be found.

Observations

Making the slivers is a time consuming activity and requires more time than making the actual product from the slivers. During the workshop, the craftsmen were cooperating with each other in several ways; they prepared slivers for each other and when they didn't remember how to make a certain product they helped each other out. There is even some kind of specialisation of tasks, which is not strange for a group of producing craftsmen.







Topali: to serve chillies



Sibanno: to serve boiled rice (Rs 60, which is 1 euro)



Khuti wali gathali topali: for collecting cow dung (Rs 50)



Topali: to serve rice, vegetables and grain (Rs 15)



Malai: fishtrap (Rs 150)



Hup: to clean rice and grain (Rs 80)



Doll: to store flowers for Gods



Karandiyo: to store vegetables (Rs 70)



Sabdi: to store rotis

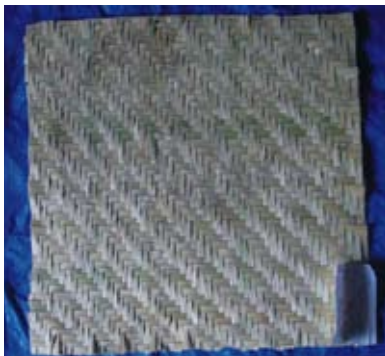

Sadari: to sit on (Rs 10)



Bhot: to store fish (Rs 70)



Kandi: basket for storing Gods (Rs 50)



Ghonagdo: to protect a person from rain (Rs 40)



Shabali: to serve rotis (Rs 15)



Dalli: to serve mangoes (Rs 20)

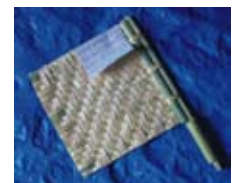

Venno: flag, used during a marriage (Rs 50)

Appendix 7 - The culture of the Kotwalia community



The Kotwalia community is a primitive landless tribal community in the southern part of Gujarat. The community is mainly known for its traditional occupation of bamboo crafts, while almost none of the families are solely dependant on bamboo crafts for their income. Most families have three sources of income, amongst which: agricultural labour, fishery, sugarcane harvesting, cattle rearing and other low skilled labour. More than 60% of the community members are illiterate and half of the households have an income of less than Rs 1500 (20 to 25 euro), while almost all households have an income below Rs 3000 (40 to 50 euro). The average household size is 4 persons (Mehta 2009).

The Kotwalia community is identified locally as Vadi (migrating group), due to their nomadic nature. As one story goes, the name Kotwalia derives from 'coat wala' (coat maker). In the early 1920's, a member of the community prepared a coat of bamboo material and presented it to a British officer. Another story about the origin of their name says that some of the community members used to work as a Kotwal (a Policeman in charge of the gate of a fort) (source: Centre for Tribal Education and Learning, Ahmedabad, 2009). Kotwalia have also been known as Vitolia (which means that their caste has ben mixed with a lower caste), Barodia and Vansfodia. The bamboo in Gujarat is called 'Vans' and the process of breaking is known as 'Fodvu'. Therefore they used to be known as Vansfodia (those who break the bamboo).

The community lives scattered among different villages in the southern part of Gujarat. Most of the people live in a kutch, a house made from bamboo, clay and wood. More affluent community members live in stone houses and might have access to electricity, running water and television. Access to good sanitation is rare.

The Kotwalia are non-vegetarian and eat fish. They buy most of their food on the local market. In early days they used to trade bamboo products for food. The community makes its own alcohol from berries.

The people of the Kotwalia community wear both western clothes as traditional Indian clothes. The elder generation wears more traditional clothes, while the younger generation only uses traditional details. The married women for instance, have a small silver ring in their nose, and wear a mangal sutra (a gold ornament) around the neck.

The community is very superstitious. To drive away bad spirits, some babies are burned with a metal stick on their belly. And when a person dies, he is carried around his house for three times, to distract his spirit and prevent it from visiting the house. During the 4-day workshop the villagers claimed that they had seen a red tiger with black spots a few days ago.

Malaria is one of the main causes of death in the community.

Bamboo

The community is known for its bamboo based craftsmanship. Though, the number of people who master the weaving of bamboo products is decreasing as the younger generation is not interested to learn the art because the income is very low. The average daily income on bamboo crafts rarely exceeds Rs 35 (50 tot 60 eurocent) a day.

The availability of bamboo differs between the villages. Some craftsmen have to walk up to 70 km to harvest bamboo in the forrest, while other villages are situated in a bamboo forrest area. Because the forrest is owned by the government and under control of

the Forest Department, harvesting bamboo without permission is considered illegal. For this reason, groups of craftsmen either steal bamboo from the forrest, or they live for a few months in the forrest to make products, which they carry back to their village all at once. Since recently, the community gets a limited harvesting allowance. Sometimes, the Kotwalia buy bamboo from private land owners for 15 to 50 Rs per pole (Reubens 2010).

The bamboo species that are being used by the community are called manvel and katis. The bamboo is harvested at the age of 2 years, at which stage the bamboo is still flexible enough for weaving baskets.



Appendix 8 - Field visit CIBART production unit, Ukai, India

To get more insight into the semi-industrial production of bamboo products, a field visit to INBAR's production unit in Ukai, Southern Gujarat is organised. INBAR - being an international organisation - is working together with CIBART (an Indian organisation) for execution of its projects in India. The local director for Gujarat is Kalpesh Dhodia.

CIBART is since recently working in three districts (Tapi, Dang and Navsari) where the Kotwalia community is settled. CIBART is managing its work with the Kotwalia community from an office in Vyara.

In Ukai (Tapi district), CIBART has set up three business units: a workshop, a treatment plant and a nursery. The three business units can function as a separate business and sell products and/or services to one of the other business units, or to other organisations.

At the high tech nursery, CIBART is growing bamboo plants that will be sold to the Kotwalia community to grow their own bamboo. The nursery has a high tech watering system. The bamboo species that is being nursed has a solid stem, which makes it very suitable for the production of furniture.

At the treatment plant, bamboo is being treated for preservation with a mixture of boric acid and borax. A pressure vessel is used to apply the chemical mixture. The bamboo stems are perforated between the nodes, to make sure the chemical reaches everywhere.

At the workshop, trained Kotwalia tribals are making products (furniture) that will be marketed and sold by CIBART. The employees are trained by CIBART for 4 months to use different types of tools and to make specific products. Of the 45 people trained, 32 are now working as employees. The workshop has a manager (Radeshan Patel) and two master craftsmen.

The workshop currently produces different types of furniture. Mats are currently not used or made.

Tools

At the workshop, four groups of tools are available: classic hand tools, simple hand tools and simple power tools and advanced power tools.

Classic hand tools

The workshop employees use a machete knife, which they also used for making traditional craft products like baskets.

Simple hand tools

CIBART trained the craftsmen to use other simple hand tools, in order to make other products. Tools that are being used:

- Saw
- Hammer
- Chisel
- Meter (for standardisation)
- Sanding paper (for finishing products)

Simple power tools

CIBART has also trained the craftsmen to work with different types of sanding machines.

Advanced power tools

Advanced power tools are used for sanding and sawing (cutting) bamboo.



Appendix 9 - Outline workshop, Ukai, India

To develop new products, a two-week workshop is prepared. Due to visa issues the graduate student was not able to join the workshop and can not present any results.

| Organisation | |
|-----------------------------|-----------------------------------------------------------|
| Gijsbert Koren | Coordinator |
| Avinash Bhandari | Coordination support (NID, Outreach Department) |
| <i>two Indian designers</i> | Participants (NID, Outreach Department) |
| <i>two Dutch designers</i> | Participants (TU Delft) |
| Shri A.M. Tiwari | Sponsor (Secretary Gujarat Tribal Development Department) |
| Kalpesh Dhodia | Facilitator (Manager CIBART Southern Gujarat) |
| Radeshnan Patel | Facilitator (Manager CIBART workshop Ukai) |

Goals

The main goal of the workshop is to generate livelihood opportunities by innovating the bamboo products that are currently being produced by tribal craftsmen. The workshop will be a meeting between designers and craftsmen, who can both learn from each other's skills. The craftsmen are very skilled in their craft, while the designers are skilled in being innovative and fitting a product design to market needs.

Deliverables

The main deliverable of the two-week workshop is a set of prototypes that can be used to showcase possibilities of applying hand woven bamboo mats in products for the urban market. From each design, at least two prototypes will be delivered; one for showing at an exhibition in the Netherlands and one for the product library of the Department of Tribal Development. Next to that, clear documentation of the designs and a report of the workshop will be delivered, so both

the designs and the workshop can be used in the future by other people. There are no claims on intellectual property rights by the organisers of the workshop; the Kotwalia community is free to use all designs for own production.

Starting points

The starting points for the prototypes to be developed are:

- Sustainability (environmental friendly)
- Made by and livelihood generation for Kotwalia craftsmen
- Fit the global urban market demands (the products should also have potential for mass production by the Kotwalia)
- Show possibilities of hand woven bamboo mats to stimulate upscaling production (and thus: the products should have a competitive pricing)

All starting points together should conclude into feasible products for the market.

Planning

Location: South Gujarat

Dates: Monday May 10 - Sunday May 23 2010

| Date | Activities |
|--------------------|----------------------------------------------------------------------------------------------------------------------|
| Monday | Travel to South Gujarat, visit villages (culture, existing products, tools) |
| Tuesday | Explore opportunities for adding more value to (existing) products (colours, weaving patterns, other materials, etc) |
| Wednesday | Pressure cooker; design a concept in 1 day and present this to the group |
| Thursday to Sunday | Design product |
| Monday to Saturday | Prototyping |
| Sunday | Travel back to Ahmedabad |

During the workshop, all participants will design a product and make prototypes. The participants will start the day with an

introduction, during which they show each other what they have done yesterday and what they are planning to do today. This way, the participants will also learn from each other and can help each other with their expertise. Each participant will work together with several craftsmen, who make the prototypes.

The product designs will be developed during the workshop itself, but they will be in the areas of:

- (Stylish) products for use at home (eg: vanity case, table set, etc.)
- Products for office use (eg: furniture, business card holder, document folder, etc.)
- High quality (gift) packaging (eg: for mangoes, sunglasses, etc.)

Support from the Department of Tribal Development

As discussed and agreed by Shri A.M. Tiwari (secretary Tribal Development Department), the workshop will be supported in the following ways:

- Material (bamboo mats) and tools for the workshop
- Craftsmen from Kotwalia community for prototyping
- Translators to communicate with the craftsmen
- A place to execute part of the workshop in the Kotwalia area
- Accommodation and food for the participating design students
- No fee or financial compensation for me/organisation

Appendix 10 - Scoring of product ideas

All ideas from the creative sessions and more are scored on the following criteria:

- Value of the product for the craftsmen
- Technology level needed for production
- Sustainability
- Remarkability
- Fit the urban consumer
- Commercial potential for me as an entrepreneur

| | Value of product | Technology level (for production) | Sustainability | Remarkability |
|-------------------------------|------------------|-----------------------------------|----------------|---------------|
| packaging | -- | ++ | - | - |
| coffee cup holder | -- | ++ | - | -- |
| baskets/cases for storage | -- | ++ | 0 | -- |
| rice bowl | -- | ++ | 0 | - |
| business card holder | - | ++ | 0 | 0 |
| iPhone case | 0 | + | 0 | + |
| laptop case | 0 | + | 0 | + |
| soap dispenser | -- | + | 0 | - |
| flip flops | -- | + | 0 | 0 |
| element of a body | -- | + | 0 | + |
| sandwich panels | -- | 0 | 0 | - |
| stapler or perforator | - | + | 0 | 0 |
| shoes | 0 | 0 | 0 | + |
| case for musical instrument | - | 0 | 0 | + |
| furniture | + | 0 | 0 | + |
| suitcase | + | 0 | 0 | 0 |
| sunglasses frame | 0 | 0 | 0 | + |
| body for consumer electronics | + | - | 0 | ++ |
| snowboard | 0 | - | 0 | + |
| helmet | - | -- | 0 | + |
| wing for urban windmill | + | -- | + | ++ |
| boat | ++ | -- | 0 | ++ |
| car body | ++ | -- | 0 | ++ |

| Fit the consumer | Commercial potential (for entrepreneur) | Total score | Comments |
|------------------|-----------------------------------------|-------------|--------------------------------------------------------------------------------------------------|
| 0 | - | - | Packaging is not sustainable in itself. |
| 0 | -- | -- | Not a very useful product. |
| 0 | - | - | Not remarkable at all. |
| 0 | - | - | Not innovative enough. |
| + | 0 | 0 | Easy to make and an eco icon for the user. |
| + | ++ | + | Also develop an iPhone app to create an experience. |
| + | + | + | A laptop is carried in a bag and not in casing. |
| 0 | - | - | Difficult to start a high quality brand in this sector. |
| 0 | - | - | Not innovative enough. |
| 0 | - | 0 | Innovativeness depends on the appliance. The profit is low, because components have a low value. |
| 0 | - | - | |
| + | 0 | 0 | Difficult to start a high quality brand in this sector. |
| 0 | 0 | 0 | |
| 0 | 0 | 0 | The cases are very expensive and have to be impact resistant. |
| + | + | + | The application of bamboo in furniture is not new, although the shapes could be innovative. |
| + | 0 | + | The impact resistance of bamboo is a good quality. |
| + | + | + | Sunglasses are probably too detailed and small. |
| + | + | + | The market of consumer electronics is difficult to enter. |
| + | + | + | Already done. |
| + | 0 | 0 | The material is not tested, so application doesn't seem viable. |
| + | + | + | A windmill aspires to the econcierge trend. |
| + | ++ | + | |
| + | ++ | + | The material is not tested, so application doesn't seem viable. |

Appendix 1 1 - iPhone cases

types of cases



carbon fiber cases



bamboo cases





Appendix 12 - Urban windmills

vertical axis urban windmills



QuietRevolution (5 kW)

€43k



Ropatec WRE 030 (3 kW)

€16k



Turby (1.9 kW)

€18k



Helix HE-40 (0.04 kW)

€2k



Windside

horizontal axis urban windmills



Gazelle (20 kW)



Proven WT6000 (6 kW)

€20k



Evance Iskra (5 kW)

€23k



Fortis Montana (2.7 kW)

€16k



WES5 Tulipo (2.5 kW)

€17k



Swift (2.5 kW)



donQi (1.8 kW)

€6k



Energy Ball (0.5 kW)

€6k



Motorwind 12 (0.1 kW)

€1k



Windwall

The figures above give an overview of urban windmills, the power they generate at a nominal wind speed of 10 m/s and the cost price (including all installation and operational costs).

The price per 100W for urban windmills varies a lot; it ranges from €300 to €4000 per 100W.

Let's do a calculation to see after how many years a household earns back its initial investment in an urban windmill. What we need to know:

- How expensive the windmill is
- How much energy a household needs
- What the price of electricity is and will be over the next years

A rough overview of the average power consumption of some domestic appliances:

| Appliance | Power |
|-------------------------|-------|
| AC (airco) | 1000W |
| Laptop | 50W |
| Desktop PC | 100W |
| Fridge | 200W |
| Lightbulb | 60W |
| Energy saving lightbulb | 20W |

The average household energy consumption:

| Country | Consumption |
|-----------------|-----------------|
| India | 1,000 kWh/year |
| the Netherlands | 3,500 kWh/year |
| USA | 10,000 kWh/year |

The price for electricity is:

| Country | Price |
|-----------------|-----------|
| India | €0.06/kWh |
| the Netherlands | €0.20/kWh |
| USA | €0.06/kWh |

The price of electricity will be rising the coming years. But, to make the calculations easier, let's suggest they will stay constant.

The average windspeed in the Netherlands is 5.5 m/s, while in India it is about half of this.

At a nominal wind speed of 12 m/s, Turby delivers 1.9 kW, but at the average wind speed in the Netherlands (5.5 m/s) it only delivers 0.18 kW (Jadranka 2007), which is a huge drop. During one year, Turby will generate more than 1,500 kWh. Which is enough for the average Indian household. However, the nominal power is 180 W, which is quite low; you can for instance power one desktop and laptop at the same time, but nothing more.

1,500 kWh will cost €90 in India and USA and €300 in the Netherlands. The total price of Turby is €18,000, so it will cost 60 years for an average Dutch household to earn back the initial investment!

This simple calculation shows that urban windmills are not economically feasible, unless:

- It is placed at a location where there is no electricity grid
- The price of electricity goes up
- The price of urban windmills goes down

Appendix 13 - Wind energy in India

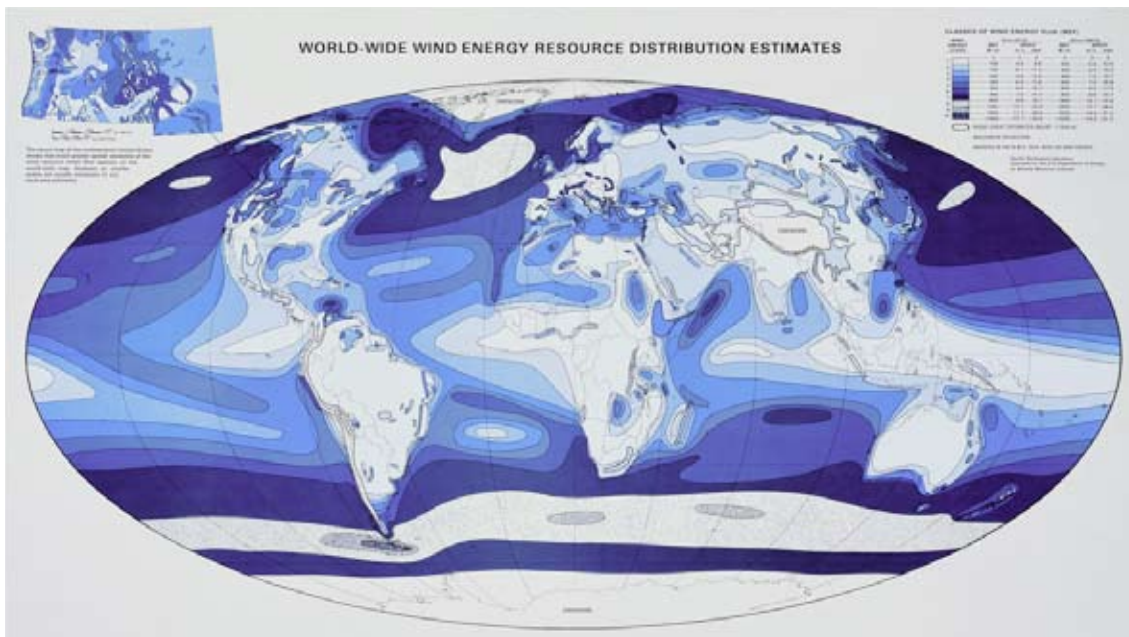

Wind energy can only be generated at geolocations with enough wind energy flux. The figure above (from 1985) gives an impression of the wind energy flux distribution over the world. It shows clearly that for instance the Netherlands is richer in wind energy than India.

The second map shows the wind energy flux distribution in India. The last map shows the wind energy hotspots plotted on a Google Maps map. It can be seen that large urban areas like Bangalore, Chennai and Ahmedabad are near wind energy hotspots.

Wind energy is an important source of renewable energy. Renewable energy is seen by many as a solution to reduce human caused climate change. Wind energy accounts for more than 1,5% of the global electricity generation (WWEA 2008) and the total installed wind energy capacity doubles every 3 years (GWEC 2008).

Although India did not seem to be wind energy rich, India has quite a few windfarms; 6% of the total installed power for electricity generation are windfarms. However, only 1,9% of the electricity generated comes from wind energy. This difference is due to a lack of good governance by the government and misuse by companies and individuals with a lot a capital, to earn money by building windfarms and not by running them. More than half of the windmills installed in India are manufactured by Suzlon, an India based company.

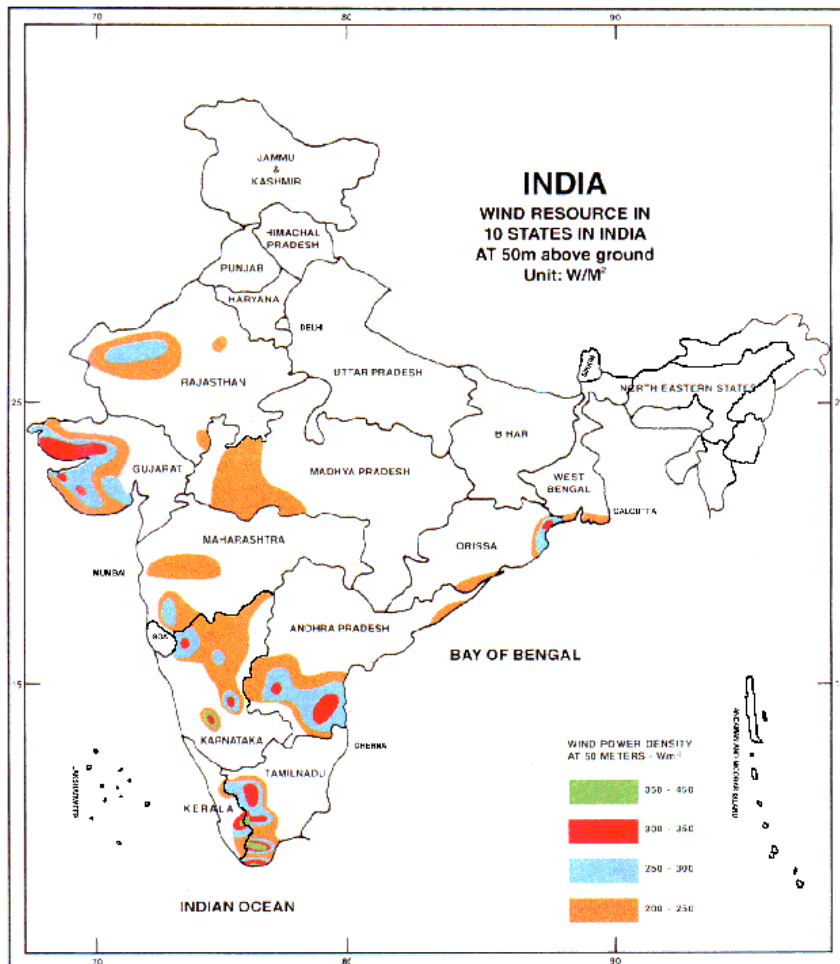

Appendix 14 - Technical drawings

Bosman windmill

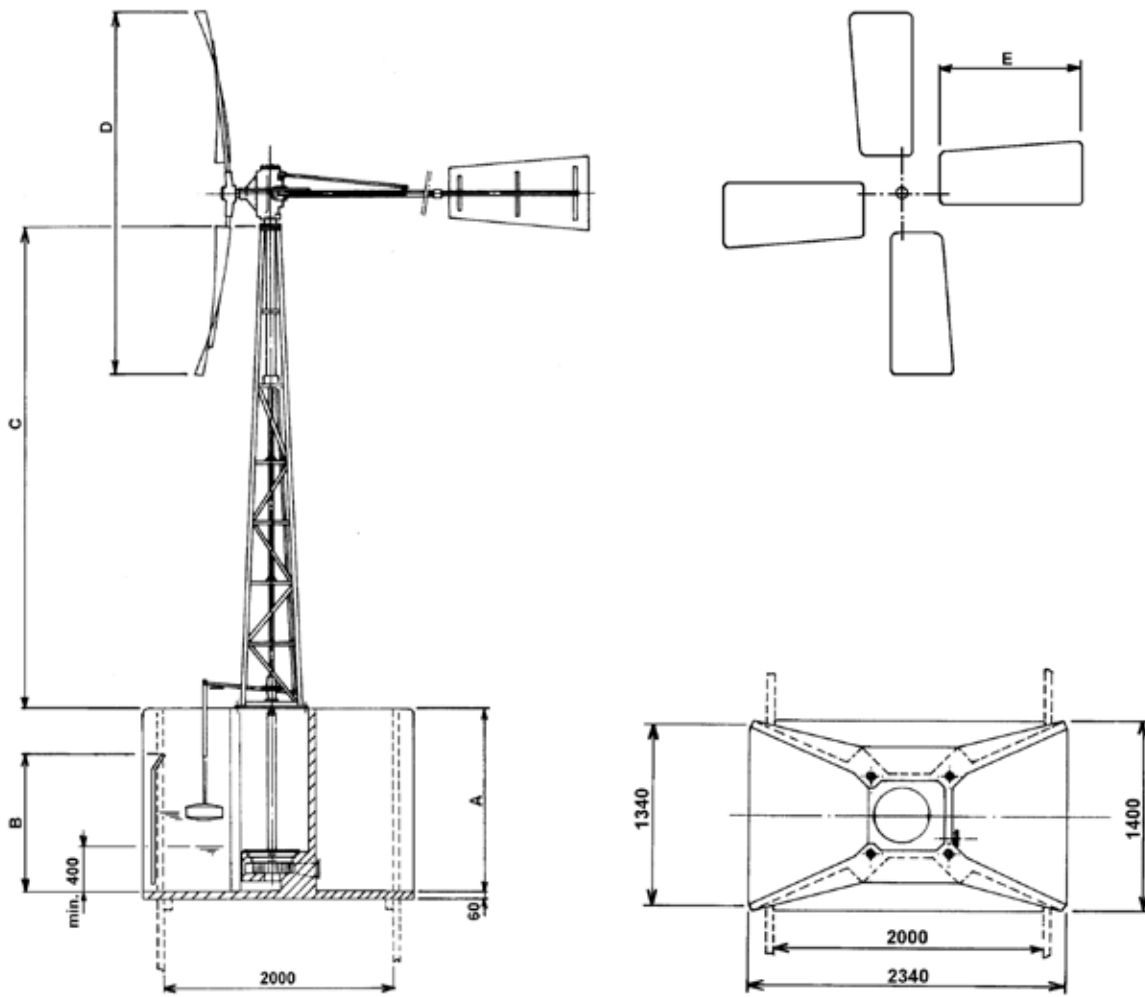

| | | | | |
|---|----|------|------|------|
| A | mm | 1530 | 2030 | 2530 |
| B | mm | 925 | 1425 | 1425 |
| C | mm | 4020 | | 7020 |
| D | mm | 3030 | | |
| E | mm | 1220 | | |

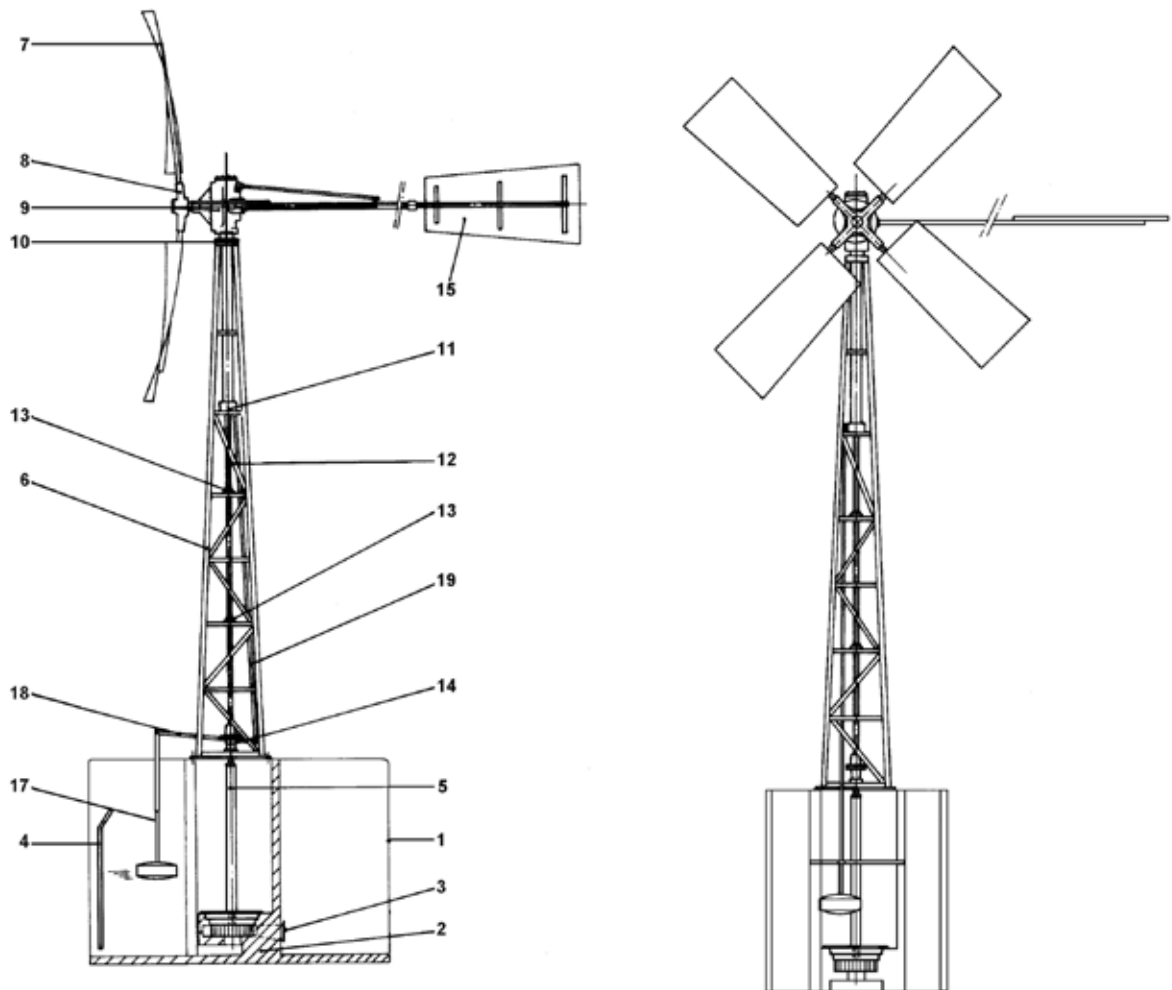

| | | | |
|-----|------------------|-----|-----------------|
| 1. | onderbouw | 11. | glijdlager |
| 2. | pomphuis | 12. | vertikale as |
| 3. | terugslagklep | 13. | tussenlagers |
| 4. | vuilrooster | 14. | flenskoppeling |
| 5. | centrifugaalpomp | 15. | hoofdstaartblad |
| 6. | toren | 16. | zijstaartblad |
| 7. | wieken | 17. | vlotter |
| 8. | wiekenkruis | 18. | evenaar |
| 9. | koptandwielhuis | 19. | stangenstelsel |
| 10. | taatslager | | |

(source: Bosman Watermanagement)

Appendix 15 - Working Stress Design

The Working Stress Design (WSD) methodology is a method of design in which structures or members are proportioned for prescribed working loads. In the case of a blade of a wind mill, the working loads are wind force and the force exerted by the construction on the blade.

Stresses that result from the two forces mentioned above are:

- Bending stress (σ_b)
- Shear stress (τ)
- Tensile stress (σ_t)

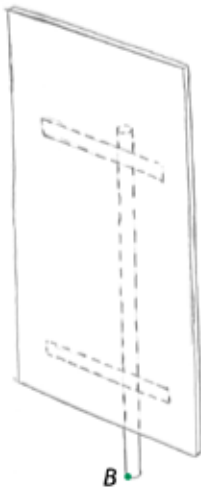

Bending stress

The shape of the blade can be reduced to a flat surface, with a lift coefficient (C_L) of 0.5 (Anderson 1999), when the blade is placed perpendicular to the windflow.

At a windspeed (v_w) of 20 m/s (8 Beaufort), the frequency (f) of the windmill is 4 Hz. One period (T) lasts 0.25 s.

The angular velocity (ω) is calculated.

$$\omega = \frac{2\pi}{T}$$

$$\omega = 25 \text{ rad/s}$$

The average rotation speed (v_r) is calculated.

$$v_r = \omega \cdot r = 25 \cdot 0.7 = 17.5 \text{ m/s}$$

The average true airspeed (v) at the blade consists of the components windspeed (v_w) and average rotation speed (v_r).

$$v = 26.6 \text{ m/s}$$

The lift force (L) is calculated.

$$L = \frac{1}{2}\rho v^2 AC_L$$

$$\rho = \text{air density} = 1.25 \text{ kg/m}^3$$

$$v = \text{average true airspeed} = 26.6 \text{ m/s}$$

$$C_L = \text{lift coefficient} = 0.5$$

$$A = \text{surface area} = 0.60 \text{ m}^2$$

$$L = 133 \text{ N}$$

The arm (a) of the lift force is 0.7 m. The resulting moment is 93 Nm.

To calculate the bending stress (σ_b), the second moment of area (I) of the bamboo shaft behind the blade is calculated.

$$I_0 = \frac{\pi}{64}(D_o^4 - D_i^4)$$

$$D_o = \text{outer diameter} = 0.05 \text{ m}$$

$$D_i = \text{inner diameter} = 0.04 \text{ m}$$

$$I = 1.8 \cdot 10^{-7} \text{ m}^4$$

Now, the bending stress (σ_b) at point B (see picture) can be calculated.

$$\sigma = \frac{My}{I_x}$$

$$M = \text{moment} = 93 \text{ Nm}$$

$$y = \text{perpendicular distance to the neutral axis} = 0.025 \text{ m}$$

$$I = \text{second moment of area} = 1.8 \cdot 10^{-7} \text{ m}^4$$

$$\sigma_b = 12.9 \text{ MPa}$$

The tensile strength (σ_y) of bamboo varies between species, age and moisture content and generally lies between 100 MPa (Laemlaksakul 2008) and 200 MPa (Jain et al 1992). Strength tests with the used bamboo material for the blade, indicate a tensile strength (σ_t) of 120 MPa. This value is taken as indicative for the tensile strength of the bamboo shaft. See the next appendix for more insight into the tests.

Taking into account a safety factor of 0.44 (INBAR 2000), the allowed stress (σ_a) is 52.8 MPa.

A unity check indicates that the actual bending stress (σ_b) at the average true air speed (v) is 24% of the allowed stress (σ_a). This means that the design can withstand the bending stress.

Shear stress

At the same average true air speed (v), the shear stress (τ) in the bamboo shaft is calculated.

$$\tau = \frac{F}{A}$$

F = drag force = 133 N
A = cross sectional area = 0.0007 m²

$\tau = 0.19$ MPa

The design can easily withstand the shear stress.

Tensile stress

At the same average true air speed (v), the tensile stress (σ_t) in the bamboo shaft is calculated.

The tensile stress (σ_t) is a result of the rotation of the blades.

The resulting centripetal force (F_c) is calculated.

$$F_c = mr\omega^2$$

m = mass of the blade = 5 kg
r = radius = 0.7 m
 ω = angular velocity = 25 rad/s

$F_c = 2211$ N

Now, the tensile stress (σ_t) in the bamboo shaft can be calculated

$$\sigma_t = \frac{F}{A}$$

F = centripetal force = 2211 N
A = cross-sectional area = 0.0007 m²

$\sigma_t = 3.1$ MPa

The design can easily withstand the tensile stress.

Conclusion

The calculations show that the design can withstand the working loads if the windspeed = 20 m/s.

Appendix 16 - Tensile strength tests

Sample 1

Two layers of bamboo mats, glued together with epoxy



Tensile strength

The maximum force that could be applied to sample 1 is 4250 N.
The tensile strength is 30.55 MPa.

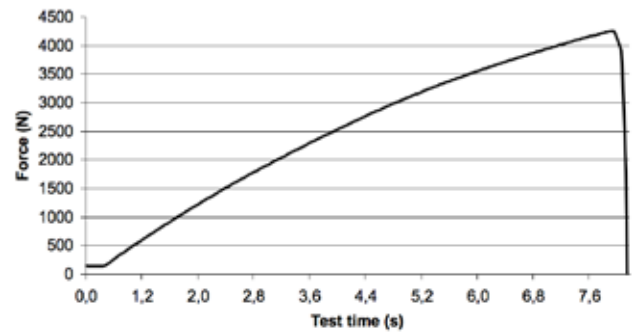

Sample 2

Two layers of bamboo mats, glued together with epoxy



Tensile strength

The maximum force that could be applied to sample 1 is 3300 N.
The tensile strength is 18.86 MPa.

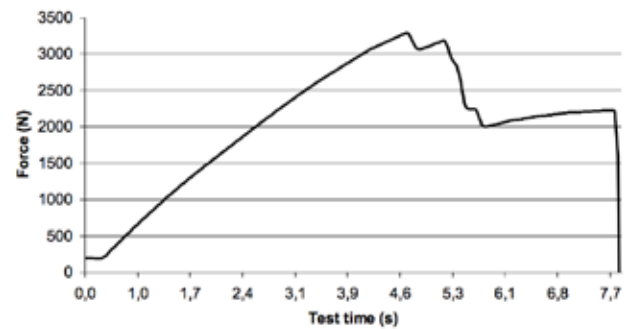

Sample 3 & 4

Bamboo strips



Tensile strength

The maximum force that could be applied to sample 1 is 1200 N.
The tensile strength is 120 MPa.

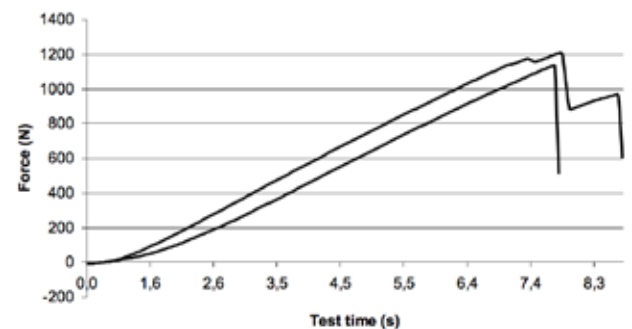

Appendix 17 - Prototyping



Vacuum bag sealing tape is fixed on a hardened glass plate which is used as mould.

fix tape



The mould is waxed with four layers of honey wax. The wax layers are air dried, after which they are rubbed off, leaving behind a smooth surface.

wax
mould

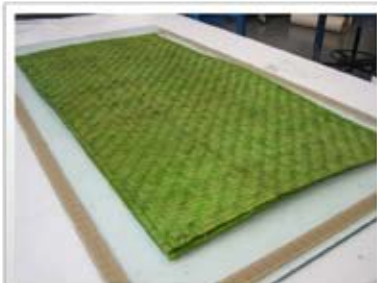

The bamboo mats are placed in position on the mould.

place
mats

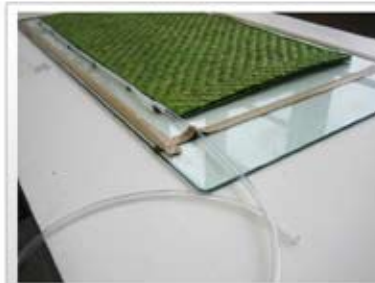

Tubes are fixed with tape on the mould. The tubes are used to transport the resin from the resin container toward the product and from the product to the overflow container.

fix
tubes

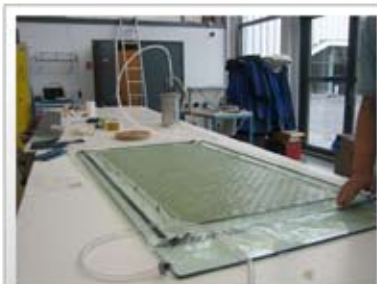

A vacuum bag is placed over the mould and fixed with the tape. A vacuum is applied by connecting one tube with a pump and closing the tube.

place
vacuum bag



Epoxy resin is mixed with cure and the closed tube is put into the resin, after which the tube is opened. The resin flows through the bamboo mats and fills all holes in the material.

apply
resin

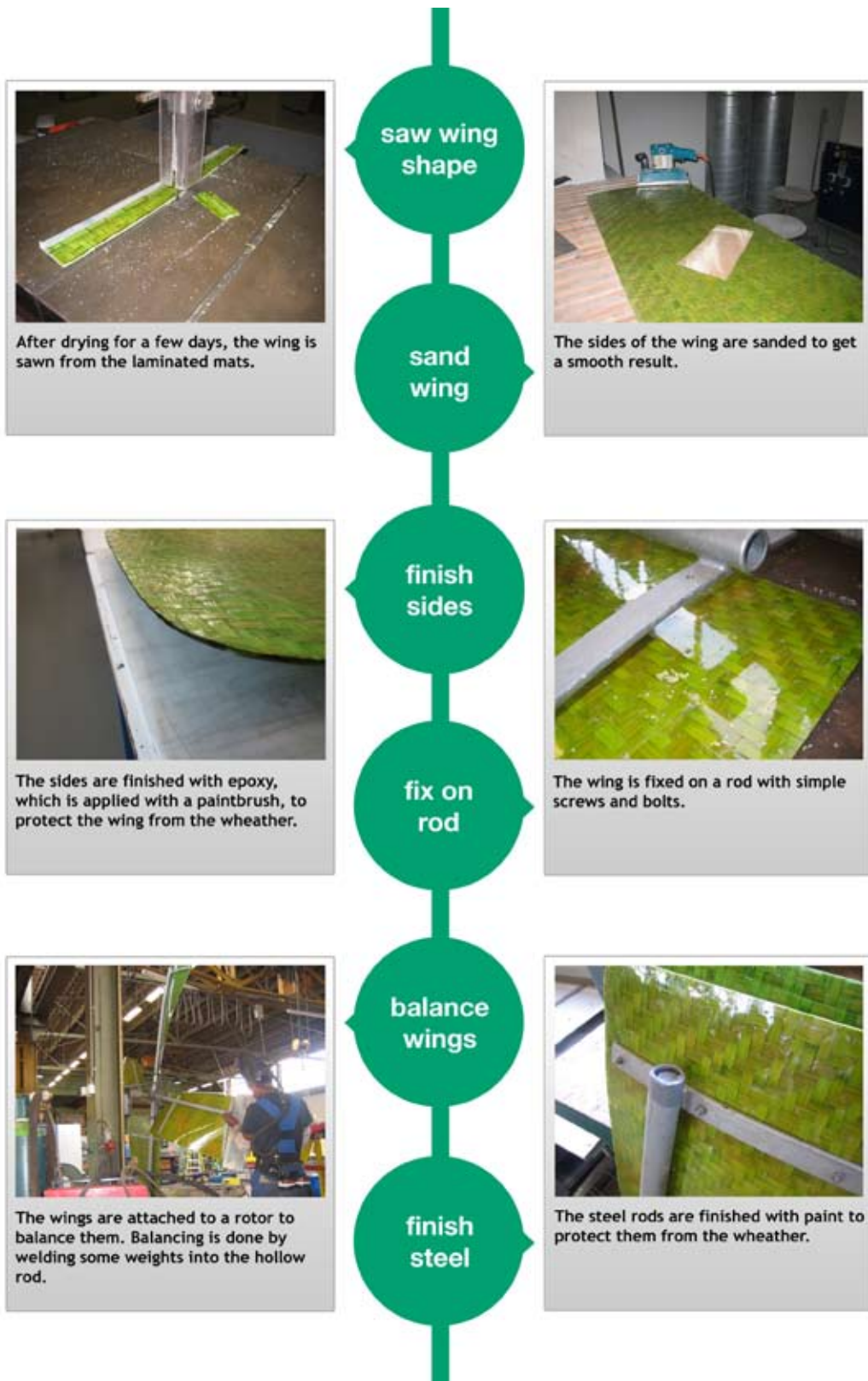

Appendix 18 - Various material samples



Bamboo mat with simple herringbone pattern (painted green)



Two layers of mats glued together with epoxy



Two layers of mats glued together with white wood glue



Two layers of mats glued together with foaming PU glue



Two bamboo mats glued on plywood (from manufacturer)



Two layers of palm leave mats glued together with white wood glue



Two layers of shital patti glued together with white wood glue

